

EUROPEAN STANDARD

**EN 13032-1:2004/AC**

NORME EUROPÉENNE

January 2005

EUROPÄISCHE NORM

Janvier 2005

Januar 2005

---

ICS 17.180.20; 29.140.01

English version  
Version Française  
Deutsche Fassung

Light and lighting - Measurement and presentation of photometric data of  
lamps and luminaires - Part 1: Measurement and file format

Lumière et éclairage - Mesure et  
présentation des données photométriques  
des lampes et des luminaires - Partie 1:  
Mesurage et format de données

Licht und Beleuchtung - Messung und  
Darstellung photometrischer Daten von  
Lampen und Leuchten - Teil 1: Messung  
und Datenformat

This corrigendum becomes effective on 26 January 2005 for incorporation in the three official language versions of the EN.

Ce corrigendum prendra effet le 26 janvier 2005 pour incorporation dans les trois versions linguistiques officielles de la EN.

Die Berichtigung tritt am 26. Januar 2005 zur Einarbeitung in die drei offiziellen Sprachfassungen der EN in Kraft.



EUROPEAN COMMITTEE FOR STANDARDIZATION  
COMITÉ EUROPÉEN DE NORMALISATION  
EUROPÄISCHES KOMITEE FÜR NORMUNG

**Management Centre: rue de Stassart, 36 B-1050 Brussels**

---

© 2005 CEN All rights of exploitation in any form and by any means reserved worldwide for CEN national Members.  
Tous droits d'exploitation sous quelque forme et de quelque manière que ce soit réservés dans le monde entier aux membres nationaux du CEN.  
Alle Rechte der Verwertung, gleich in welcher Form und in welchem Verfahren, sind weltweit den nationalen Mitgliedern von CEN vorbehalten.

Ref. No.: EN 13032-1:2004/AC:2005 D/E/F

### **English version**

The Date of Withdrawal of conflicting national standards (DOW) is to be **2008-01-31**.

### **Version française**

La date de retrait de toutes les normes nationales en contradiction (DOW) doit être **2008-01-31**.

### **Deutsche Fassung**

Das Datum der Zurückziehung etwaiger entgegenstehenden nationalen Normen (DOW) muss **2008-01-31** sein.

EUROPEAN STANDARD

**EN 13032-1**

NORME EUROPÉENNE

EUROPÄISCHE NORM

July 2004

ICS 17.180.20; 29.140.01

English version

**Light and lighting - Measurement and presentation of  
photometric data of lamps and luminaires - Part 1: Measurement  
and file format**

Lumière et éclairage - Mesure et présentation des données  
photométriques des lampes et des luminaires - Partie 1:  
Mesurage et format de données

Licht und Beleuchtung - Messung und Darstellung  
photometrischer Daten von Lampen und Leuchten - Teil 1:  
Messung und Datenformat

This European Standard was approved by CEN on 16 January 2004.

CEN members are bound to comply with the CEN/GENELEC Internal Regulations which stipulate the conditions for giving this European Standard the status of a national standard without any alteration. Up-to-date lists and bibliographical references concerning such national standards may be obtained on application to the Central Secretariat or to any CEN member.

This European Standard exists in three official versions (English, French, German). A version in any other language made by translation under the responsibility of a CEN member into its own language and notified to the Central Secretariat has the same status as the official versions.

CEN members are the national standards bodies of Austria, Belgium, Cyprus, Czech Republic, Denmark, Estonia, Finland, France, Germany, Greece, Hungary, Iceland, Ireland, Italy, Latvia, Lithuania, Luxembourg, Malta, Netherlands, Norway, Poland, Portugal, Slovakia, Slovenia, Spain, Sweden, Switzerland and United Kingdom.



EUROPEAN COMMITTEE FOR STANDARDIZATION  
COMITÉ EUROPÉEN DE NORMALISATION  
EUROPÄISCHES KOMITEE FÜR NORMUNG

**Management Centre: rue de Stassart, 36 B-1050 Brussels**

## Contents

	page
Foreword.....	4
Introduction.....	5
1 Scope .....	6
2 Normative references .....	6
3 Terms and definitions .....	6
4 Co-ordinate system .....	7
4.1 General.....	7
4.2 System of measuring planes .....	8
4.2.1 General.....	8
4.2.2 B-planes.....	8
4.2.3 C-planes.....	10
4.2.4 Relationships between the plane systems .....	12
5 Laboratory requirements for tests .....	13
5.1 General.....	13
5.2 Test conditions .....	13
5.2.1 Test room.....	13
5.2.2 Test voltage.....	13
5.2.3 Ambient temperature.....	13
5.2.4 Air movement.....	15
5.2.5 Stabilization of the light source .....	15
5.3 Electrical power supply.....	15
5.3.1 Current handling capacity .....	15
5.3.2 Stability of supply voltage .....	15
5.3.3 AC frequency .....	15
5.3.4 AC waveform.....	15
5.3.5 DC ripple.....	15
5.3.6 Electro-magnetic field .....	16
5.4 Luminous intensity distribution measurements .....	16
5.5 Luminous flux measurements.....	16
5.6 Luminance measurements .....	16
5.7 Photometric factors .....	17
5.8 Luminaires for test .....	17
6 Requirements for measurement .....	20
6.1 General aspects .....	20
6.1.1 Goniophotometers.....	21
6.1.2 Integrating photometers .....	22
6.1.3 Illuminance meters .....	24
6.1.4 Luminance meters .....	26
6.2 Measurement uncertainties .....	27
7 Basic data format requirements.....	28
8 Electronic transfer of luminaire data.....	28
8.1 General.....	28
8.2 File format.....	28
Annex A (informative) Screening against stray light.....	29
Annex B (normative) Properties of photometers .....	30
B.2.1 Definition .....	30
B.2.2 Measurement.....	31

<b>B.2.3</b>	<b>Characterization</b> .....	<b>31</b>
<b>B.3.1</b>	<b>Definition</b> .....	<b>32</b>
<b>B.3.2</b>	<b>Measurement</b> .....	<b>32</b>
<b>B.3.3</b>	<b>Characterization</b> .....	<b>32</b>
<b>B.4.1</b>	<b>Directional response for the measurement of illuminance</b> .....	<b>33</b>
<b>B.4.2</b>	<b>Directional response for the measurement of luminance</b> .....	<b>35</b>
<b>B.5.1</b>	<b>Description</b> .....	<b>38</b>
<b>B.5.2</b>	<b>Measurement</b> .....	<b>38</b>
<b>B.5.3</b>	<b>Characterization</b> .....	<b>39</b>
<b>B.6.1</b>	<b>Description</b> .....	<b>39</b>
<b>B.6.2</b>	<b>Measurement</b> .....	<b>39</b>
<b>B.6.3</b>	<b>Characterization</b> .....	<b>39</b>
<b>B.7.1</b>	<b>Description</b> .....	<b>40</b>
<b>B.7.2</b>	<b>Measurement</b> .....	<b>40</b>
<b>B.7.3</b>	<b>Characterization</b> .....	<b>40</b>
<b>B.8.1</b>	<b>Definition</b> .....	<b>40</b>
<b>B.8.2</b>	<b>Measurement</b> .....	<b>41</b>
<b>B.8.3</b>	<b>Characterization</b> .....	<b>41</b>
<b>B.10.1</b>	<b>Definition</b> .....	<b>42</b>
<b>B.10.2</b>	<b>Measurement</b> .....	<b>42</b>
<b>B.10.3</b>	<b>Characterization</b> .....	<b>42</b>
<b>B.11.1</b>	<b>Description</b> .....	<b>43</b>
<b>B.11.2</b>	<b>Measurement</b> .....	<b>43</b>
<b>B.11.3</b>	<b>Characterization</b> .....	<b>43</b>
<b>B.12.1</b>	<b>Description</b> .....	<b>44</b>
<b>B.12.2</b>	<b>Lower and upper frequency limits</b> .....	<b>44</b>
<b>B.13.1</b>	<b>Definition</b> .....	<b>45</b>
<b>B.13.2</b>	<b>Measurement</b> .....	<b>45</b>
<b>B.13.3</b>	<b>Characterization</b> .....	<b>45</b>
<b>Annex C (normative) Testing of mirrors for variation in reflectance and flatness</b> .....		<b>46</b>
<b>Annex D (normative) CEN File Format</b> .....		<b>47</b>
<b>Annex E (informative) Examples of the CEN File Format</b> .....		<b>59</b>
<b>Bibliography</b> .....		<b>62</b>

## Foreword

This document (EN 13032-1:2004) has been prepared by Technical Committee CEN/TC 169 "Light and Lighting", the secretariat of which is held by DIN.

This European Standard shall be given the status of a national standard, either by publication of an identical text or by endorsement, at the latest by January 2005, and conflicting national standards shall be withdrawn at the latest by January 2005.

Acknowledgement is given to CIE for their help in the preparation of this standard.

The European Standard 13032 *Light and lighting - Measurements and presentation of photometric data of lamps and luminaires* is published in the following parts:

*Part 1: Measurement and file format.*

*Part 2: Presentation of data for indoor and outdoor work places.*

*Part 3: Emergency lighting (in preparation).*

*Part 4: Sports lighting (in preparation).*

*Part 6: Tunnel lighting (in preparation).*

The annexes A and E are informative. The annexes B, C and D are normative.

According to the CEN/CENELEC Internal Regulations, the national standards organizations of the following countries are bound to implement this European Standard: Austria, Belgium, Cyprus, Czech Republic, Denmark, Estonia, Finland, France, Germany, Greece, Hungary, Iceland, Ireland, Italy, Latvia, Lithuania, Luxembourg, Malta, Netherlands, Norway, Poland, Portugal, Slovakia, Slovenia, Spain, Sweden, Switzerland and United Kingdom.

## Introduction

The provision of reliable and accurate photometric data is a basic requirement for any lighting engineer in order to design a good lighting scheme.

This European Standard aims to put on a common basis current European lighting practices so that a luminaire with its associated performance data, purchased in one country, can be directly compared and accurately employed in another country.

The standard is a guide to procedures referring where necessary to the relevant CIE, ISO and CEN publications.

The reliability of these data depends also on well defined qualifications about the management, the organisation and the metrological referability of the Laboratory and the skill of the staff.

## 1 Scope

This European Standard establishes general principles for the measurement of basic photometric data for lighting application purposes.

It establishes the measurement criteria needed for the standardisation of basic photometric data and details of the CEN file format for electronic data transfer.

This is part 1 of a multi part standard. Part 1 deals with the basic photometric measurement and file format. Other parts deal with lamps and luminaires data depending on the applications.

## 2 Normative references

This European Standard incorporates by dated or undated reference, provisions from other publications. These normative references are cited at the appropriate places in the text, and the publications are listed hereafter. For dated references, subsequent amendments to or revisions of any of these publications apply to this European Standard only when incorporated in it by amendment or revision. For undated references the latest edition of the publication referred to applies (including amendments).

EN 12665:2002, *Light and lighting - Basic terms and criteria for specifying lighting requirements*.

ISO 9660, *Information processing – Volume and file structure of CD-ROM for information interchange*.

## 3 Terms and definitions

For the purposes of this European Standard, the terms and definitions given in EN 12665 together with the following apply.

### 3.1

#### **light source**

lamp or luminaire

### 3.2

#### **photometric centre**

point in a luminaire or lamp from which the photometric distance law operates most closely in the direction of maximum intensity

NOTE It is the origin of the coordinate system used for the measuring of luminous intensity distribution and should be specified.

### 3.3

#### **limiting photometric distance**

minimum distance for deriving the luminous intensity from the measured illuminance

### 3.4

#### **relative measurement**

measurement obtained as a ratio of two quantities of the same type expressed in arbitrary units. Photometric measurement in SI units relative to specified bare lamp flux

[CIE 121:1996, definition 2.3.2]



### 3.5

#### **luminaire data per 1 000 lm (of lamp flux)**

photometric data of luminaire relative to a total theoretical luminous flux of 1 000 lm from all the lamps of the luminaire, when these are operated outside the luminaire under reference conditions but with the same ballast(s)

### 3.6

#### **luminous intensity distribution (of a luminaire)**

distribution of luminous intensity with direction. The luminous intensity distribution may be represented by numerical tables or by graphics and is usually expressed in units of candelas per 1 000 lm of lamp flux

## 4 Co-ordinate system

### 4.1 General<sup>1)</sup>

The determination of the intensity distribution involves the use of a co-ordinate system in order to define the direction in which the intensity measurements are made; the system used is a spherical co-ordinate system with the centre coincident with the photometric centre of the luminaire.

From a general point of view the co-ordinate system consists in a group of planes with a single axis of intersection: the polar axis. In this system a direction in space is characterised by two angles:

- a)- the angle between the plane taken as a conventional origin and the half plane containing the considered direction;
- b) - the angle between the polar axis and the considered direction or the complement of this angle.

The orientation of this system with respect to the first axis and the second axis (see Figure 1) of the luminaire is chosen with particular regard to the type of luminaire, to the type of lamp, to the mounting attitude of the luminaire and its application, in order to perform more accurate measurements or to simplify the consequent lighting calculations.

The identification of the first axis and the second axis shall be defined by the manufacturer or the photometric laboratory according to this standard. The third axis is the axis containing the photometric centre and perpendicular to the two first axes. For information on the location of the photometric centre see clause 5.8.

**NOTE** Usually the first axis of a luminaire is perpendicular to the light emitting area of the luminaire. As the light emitting area is not always clearly defined and could be curved, the relationship between this axis and a mechanical feature of the luminaire should be declared (e.g., the design attitude for road luminaires or the front glass for floodlights and for ceiling mounted luminaires the surface upon which the luminaire is mounted).

---

<sup>1)</sup> See CIE 121, 3.3.

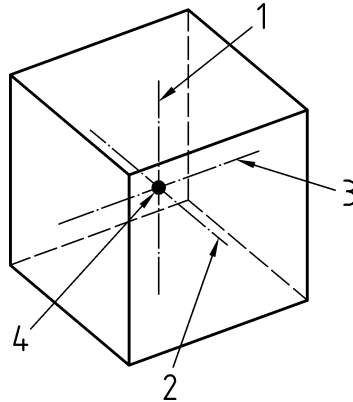

**Key**

- 1 First axis
- 2 Second axis
- 3 Third axis
- 4 Photometric centre

**Figure 1 — Photometric centre and photometric axes of the luminaire**

**4.2 System of measuring planes**

**4.2.1 General**

In general the luminous intensity distribution of a luminaire is measured in a number of planes. From the variety of possible measuring planes three systems of planes have been historically used and were identified by the CIE as A-, B- and C-planes. The same terminology is adopted in this standard, but A-planes system is disregarded.

The C-planes system is to be considered as the recommended standard system.

The B-planes system may also be used, in particular for the photometry of luminaires such as floodlights.

Any two of these planes with an angular difference of 180° will form a plane in the mathematical sense.

**4.2.2 B-planes<sup>2)</sup>**

The totality of B-planes (see Figure 2) is the group of planes for which the line of intersection (polar axis) goes through the photometric centre and is parallel to the second axis of the luminaire.

B-planes are marked with angles  $B_x$  with  $-180^\circ \leq B_x \leq +180^\circ$ . Within a plane directions are given by the angle  $\beta$  with  $-90^\circ \leq \beta \leq +90^\circ$ . The system of B-planes is coupled rigidly to the light source and follows its tilt if the luminaire is tilted.

The photometric centre of the luminaire lies in the centre of the co-ordinate system.

The first axis of the luminaire lies in plane  $B_0$ , is perpendicular to the polar axis through the photometric centre and points in the direction  $\beta = 0^\circ$ .

The second axis of the luminaire is coincident with the polar axis.

---

<sup>2)</sup> See CIE 121, 3.4.2.

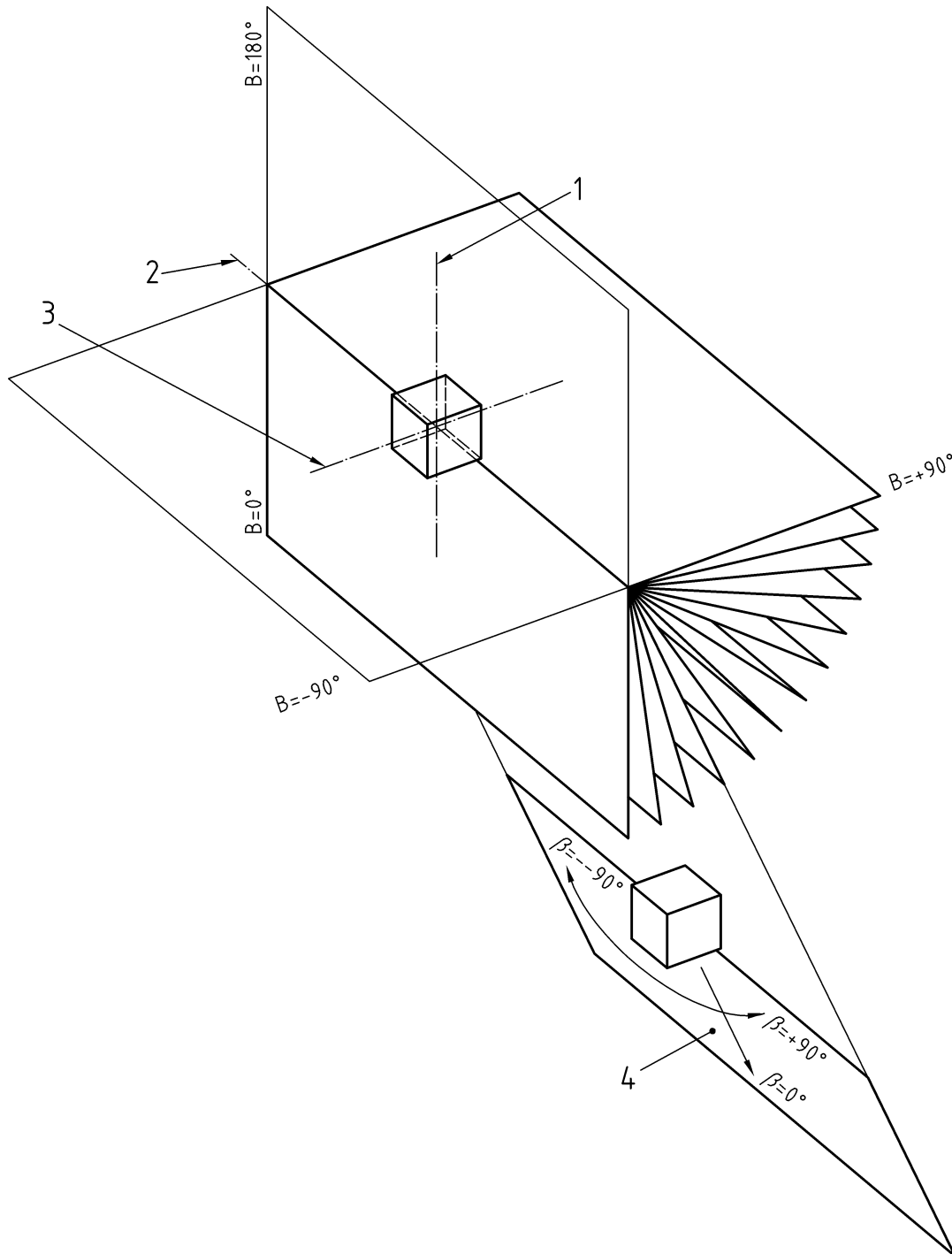

**Key**

- 1 First axis
- 2 Second axis, polar axis
- 3 Third axis
- 4 Page = B-Plane

**Figure 2 — Luminaire orientation for B-planes**

Conventions related to the choice of axes linked to the luminaire:

- 1) The first axis of the luminaire is the axis through the photometric centre and perpendicular to the plane which is representative for the main light emitting area.

## EN 13032-1:2004 (E)

- 2) For floodlights the second axis of the luminaire generally is parallel to the spigot or tilting axis of the luminaires. If orientation of the lamp requires a different orientation of the second axis, it shall be stated by the lamp manufacturer or the photometric laboratory.
- 3) For luminaires other than floodlights containing linear single or double ended lamps, the axis of the lamp or the geometric axis of multiple lamps, is chosen as the third axis of the luminaire, perpendicular to the two first ones. Thus the transverse plane to the lamps of the luminaire, which is generally the most extensive light emitting plane, lies in the  $B_0$  plane (for luminaires with a symmetry in this transverse plane in  $B_0 / B_{180}$  plane).
- 4) For other luminaires with the lamp axis coincident with the first axis of the luminaire, for other luminaires with multiple lamps or for other luminaires where no lamp axes can be defined, the luminaire shall be orientated that:
  - a) the maximum intensity  $I_{\max}$  of the light distribution is within the  $B_0$  plane or if  $I_{\max}$  is located at  $\beta = 0^\circ$  or if there are more than one location of  $I_{\max}$ ;
  - b) the  $B_0 / B_{180}$  plane is the symmetry plane of the luminous intensity distribution with the highest degree of symmetry.

If the convention 1) or 2) is applicable or if different conventions are used, the choice of luminaires axes shall be stated by the manufacturer or the photometric laboratory, so as to clearly identify the luminaire alignment in the co-ordinate system, both for photometric measurements and for lighting calculations.

### 4.2.3 C-planes<sup>3)</sup>

The totality of C-planes (see Figure 3) is the group of planes for which the line of intersection (polar axis) is the vertical line through the photometric centre. The polar axis does not necessarily coincide with the first axis of the luminaire, if the luminaire is tilted during measurements.

C-planes are marked with angles  $C_x$  with  $0^\circ \leq C_x < 360^\circ$ . Within a plane directions are given by the angle  $\gamma$  with  $0^\circ \leq \gamma \leq 180^\circ$ . The direction  $\gamma = 0^\circ$  is oriented to the nadir.

---

<sup>3)</sup> See CIE 121, 3.4.3.

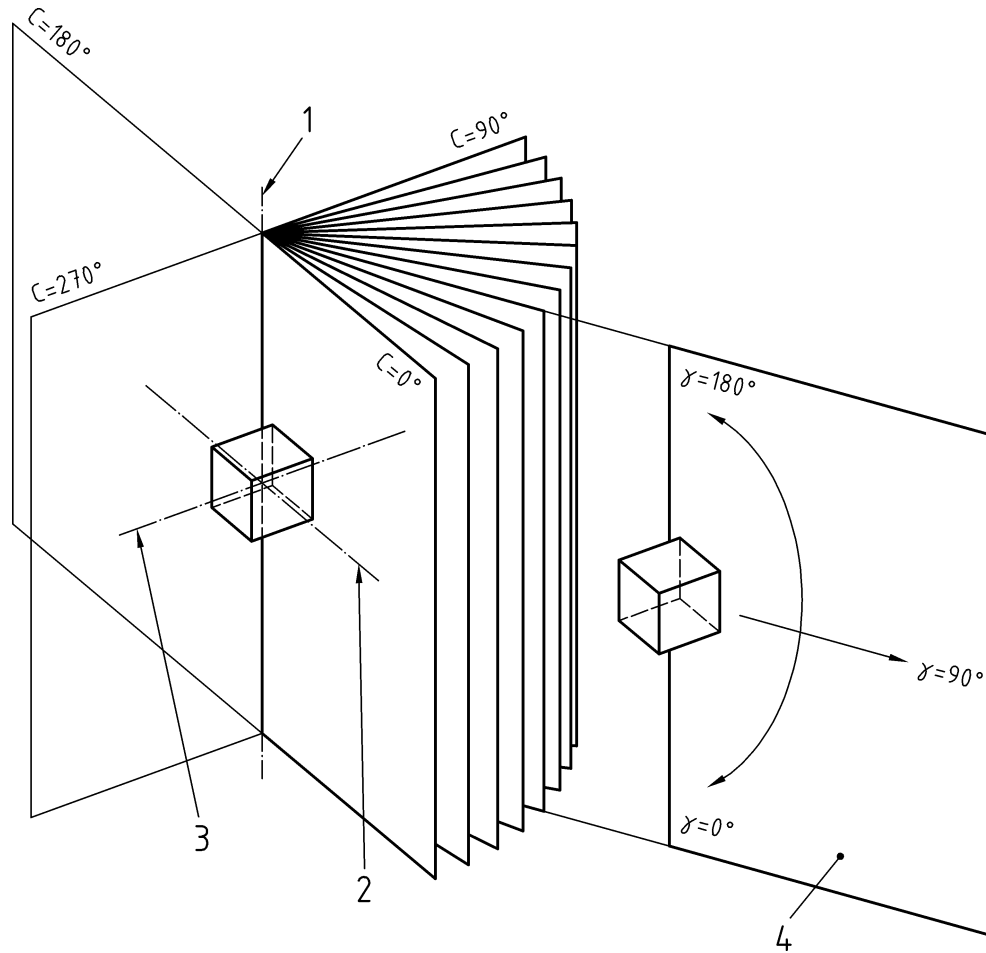

**Key**

- 1 First axis, polar axis
- 2 Second axis
- 3 Third axis
- 4 Page = C-plane

**Figure 3 — Luminaire orientation for C-planes**

The system of C-planes is oriented rigidly in space and does not follow a tilt of the luminaire.

If the luminaire is tilted during measurement (the polar axis is not coincident with the first axis of the luminaire), the angle of tilt should be declared (see Figure 4).

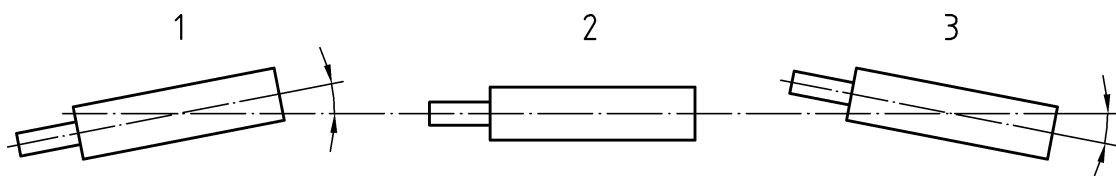

**Key**

- 1 Positive tilt angle
- 2 Zero tilt angle
- 3 negative tilt angle

**Figure 4 — Definition of tilt angle**

Conventions related to the choice of axes linked to the luminaire:

- 1) The first axis of the luminaire is the axis through the photometric centre and perpendicular to the plane which is representative of the main light emitting area.
- 2) For luminaires containing linear single or double ended lamps, the axis of the lamp or the geometric axis of multiple lamps, is chosen as the third axis of the luminaire, perpendicular to the two first ones. It means that the transverse plane to the lamps of the luminaire, which is generally the most extensive light emitting plane, lies in the  $C=0$  plane (for luminaires with a symmetry in this transverse plane in  $C_0 / C_{180}$  plane).
- 3) For luminaires with the lamp axis coincident with the first axis of the luminaire, for luminaires with multiple lamps or for luminaires where no lamp axes can be defined, the luminaire shall be orientated that:
  - a) the maximum intensity  $I_{max}$  of the light distribution is within the  $C_0$  plane or if  $I_{max}$  is located at  $\gamma = 0^\circ$  or if there are more than one location of  $I_{max}$ ;
  - b) the  $C_0 / C_{180}$  plane is the symmetry plane of the luminous intensity distribution with the highest degree of symmetry.

If the latest convention 1) or 2) is applicable or if different conventions are used, the choice of luminaires axes shall be stated by the manufacturer or the photometric laboratory, as to clearly identify the luminaire alignment in the co-ordinate system, as well for photometric measurements as for lighting calculations.

NOTE For road lighting calculations, the usual convention is that the  $C_0 / C_{180}$  intensity planes lie parallel to the road. This is normally the case for most transversely mounted luminaires, but not for luminaires with linear lamp(s) where the lamp axis is parallel to the road axis.

#### 4.2.4 Relationships between the plane systems<sup>4)</sup>

The value of the light intensity measured in a certain direction is independent of the way the direction is presented. Generally the values of each of the two angles are different for any direction in the aforementioned plane systems. The angular values of one plane system can be converted into the corresponding angular values of another plane system if the relationships given in the following Table 1 are used. The relationships are only valid if the tilt angle of the luminaire in the C-plane system is zero and as far as the second axis of the luminaire respects the conventions for luminaire orientations in the two co-ordinate systems.

**Table 1 — Conversion equations for plane systems**

Orientation Planes		For Conversion of Angles	
Given	Wanted	For Planes	For Angles
$B, \beta$ $C, \gamma$	$C, \gamma$ $B, \beta$	$\tan C = \sin B / \tan \beta$ $\tan B = \sin C \times \tan \gamma$	$\cos \gamma = \cos B \times \cos \beta$ $\sin \beta = \sin C \times \sin \gamma$

NOTE In some countries, the defined B-planes system has also been named A-planes system. To avoid confusion with the co-ordinate systems originally defined by CIE, A-plane name for this system is not recommended.

<sup>4)</sup> See CIE 121, 3.4.4.

## 5 Laboratory requirements for tests

### 5.1 General<sup>5)</sup>

The object of the tests is to measure the characteristics of the luminaire by means of appropriate equipment and procedures under the following test conditions which are comparable between laboratories and which relate as closely as practicable to the typical conditions of service for which the luminaire is designed.

### 5.2 Test conditions

#### 5.2.1 Test room

Measuring location: A luminaire shall be measured in surroundings so arranged that the photometer head receives only light from the luminaire direct or with intended reflection. Stray light shall be minimised according to the requirements in annex A.

#### 5.2.2 Test voltage<sup>6)</sup>

The test voltage at the supply terminals shall be the rated lamp voltage or the rated circuit voltage appropriate to the lamp control gear in use, if any.

The voltage shall be controlled in accordance with Table 2.

#### 5.2.3 Ambient temperature<sup>7)</sup>

The mean ambient temperature,  $T_m$ , shall equal  $(25 \pm 1)$  °C throughout the test of the light source, except where larger tolerances are indicated in table 2.

If the temperature for which the nominal luminous flux of a fluorescent lamp is published is other than 25 °C, a correction factor, supplied by the lamp manufacturer, shall be applied by the laboratory.

The ambient temperature shall be measured at a horizontal distance not exceeding 1,5 m to the surface of the light source with the lamps switched on.

Photometric measurements not made in accordance with the mean ambient test temperature shall have correction factors applied to the individual readings.

---

<sup>5)</sup> See CIE 121, 4.1 and 4.3.

<sup>6)</sup> See CIE 121, 4.2.5.

<sup>7)</sup> See CIE 121, 4.3.1.

Table 2 — Overview of selected requirements and operating conditions for light sources

Requirement	Incandescent and Halogen Lamps	Fluorescent Lamps	High Pressure Mercury Lamps	Metal Halide Lamps	Low Pressure Sodium Lamps	High Pressure Sodium Lamps
Stability of Supply Voltage	$\pm 0,1\%$ for DC $\pm 0,2\%$ for AC	$\pm 0,2\%$				
Repeatability of Luminous Flux	$\pm 1\%$ for DC $\pm 2\%$ for AC	$\pm 2\%$ 1)				
Ageing of the Lamps 2)	1 h or 1 % of life if less than 100 h	100 h, with 10 min off eight times per 24 h	100 h with 15 min off every 6 h	100 h in the position used for test	100 h with 15 min off every 6 h	100 h with 15 min off every 6 h
Stabilization Time of light source 3)	Measurement of intensity shall be taken at least once per min. No pair of reading shall differ by more than 1 % of the minimum. If this is not feasible the real fluctuation shall be stated. Compact fluorescent lamps, T 5 - lamps shall be restabilized at least 16 hours after destabilization (e. g., by shock or change in operating position). Lamps shall be cooled down in measurement position; at least the cooling down time of the lamp type under consideration shall be applied.					
Cooling Times of the Lamps	$\geq 10$ min			$\geq 15$ min	$\geq 10$ min	
Operating Position of the Lamp	Vertical, base up, if not specified else by the lamp manufacturer	Tubular and ring shaped fluorescent lamps: horizontal, Compact fluorescent lamps: vertical, base up, if not specified else by the lamp manufacturer	Vertical, base up, if not specified else by the lamp manufacturer	As specified by the lamp manufacturer	Horizontal, if not otherwise specified by the lamp manufacturer	
Ambient Temperature	(20 to 27) °C $\pm 3$ °C 4)	(25 $\pm 1$ ) °C	(20 to 27) °C $\pm 3$ °C 4)			
Remarks	For luminous flux measurements of lamps special four pin sockets shall be applied to determine the electrical data	Double ended metal halide lamps and high pressure sodium lamps up to 400 W shall be measured using a quartz tube for luminaire simulation, the results shall be corrected due to the loss in luminous flux in the luminaire simulator.				
1) $\pm 1\%$ for low pressure induction lamps. 2) The switching periods given here for the ageing of test lamps are not valid for the determination of the average life time of discharge lamps. 3) Electric and photometric stability of the individual light source under consideration shall be reached in any case; the ballast used shall be in thermal equilibrium too. 4) The temperature shall be selected between 20 °C and 27 °C, but shall not vary more than $\pm 3$ °C throughout the test.						



#### **5.2.4 Air movement<sup>8)</sup>**

The movement of air around the light source under test will reduce the operating temperature, and in consequence the luminous flux of some types of lamps will change. Such movement of air may be caused by draughts, air conditioning or motion of light source in the photometer. The air movement caused by self heating of the light source shall be ignored.

Air movement in the vicinity of light sources sensitive to temperature variation shall not exceed 0,2 m/s.

NOTE For lamps highly sensitive to temperature variations a smaller value may be necessary.

#### **5.2.5 Stabilization of the light source**

Measurement shall not be started until the light source has stabilised photometrically, see Table 2. At the end of the measurement (and regularly during a long series of tests) a return should be made to the initial position (e.g. 0° in elevation with a goniophotometer) to check that the initial photometric reading is maintained within  $\pm 1\%$ .

For lamp types other than those listed in Table 2 test conditions should be selected to meet the repeatability requirements of  $\pm 2\%$ .

### **5.3 Electrical power supply<sup>9)</sup>**

#### **5.3.1 Current handling capacity**

The power supply shall be of ample current handling capacity for the loads to be connected. In particular the supply, including ancillary transformers, shall be of very low impedance.

#### **5.3.2 Stability of supply voltage**

The voltage at the supply terminals of the luminaire and lamps shall be set and maintained at a constant value, within the tolerances given in Table 2.

#### **5.3.3 AC frequency**

The frequency of supply voltage shall be maintained constant within  $\pm 0,5\%$  of the required frequency.

#### **5.3.4 AC waveform**

The total harmonic content of the voltage waveform of an AC supply shall be as low as possible, and shall not exceed 3 % of the fundamental, except that where only incandescent lamp luminaires are to be measured this requirement may be relaxed.

#### **5.3.5 DC ripple**

If DC is applied, the voltage at the input terminals of the luminaire shall not contain more than 0,5 % of AC component.

---

<sup>8)</sup> See CIE 121, 4.3.2.

<sup>9)</sup> See CIE 121, 4.5.1.

### 5.3.6 Electro-magnetic field

The electro-magnetic field caused by the electric power supply and by the luminaire or bare lamp supply circuit shall not affect the electrical or photometric measurement equipment.

## 5.4 Luminous intensity distribution measurements

The luminous intensities emitted by a light source in different directions are measured with a goniophotometer and be expressed for luminaires usually in units of candela per 1 000 lumens and for lamps in candelas.

For very high or very low luminous intensities a multiplier may be used.

NOTE Guidance for intensity distribution measurements is given in CIE Publication 70.

## 5.5 Luminous flux measurements

The luminous flux of the luminaire and the bare lamp is usually determined by luminous intensity integration methods using the same goniophotometer for both measurements. Where luminous flux measurements are necessary on bare lamps an intergrating photometer may be used.

NOTE Guidance for luminous flux measurements is given in CIE Publication 84.

If an integrator, spherical or otherwise in shape, is used for light output ratio measurements, then it shall be ensured that differences in the luminous intensity distributions of the lamp and luminaire do not influence the accuracy significantly. This shall be checked by comparing results obtained in the integrator with the corresponding results obtained within a goniophotometer which complies with the requirements of clause 6. The value of light output ratio obtained by each of the two methods shall not differ by more than  $\pm 2\%$ .

## 5.6 Luminance measurements

The following procedures shall be followed when measuring either the average luminance of a luminaire or the luminance of a stated luminous patch:

- 1) The average luminance of the luminaire in a stated direction, or in a series of directions. The luminous intensity shall be measured with a goniophotometer and the luminance shall be calculated by dividing it by the projected luminous area.
- 2) The luminance of a stated luminous patch in a stated direction (usually part of a scan of the luminaire to find the maximum luminance in a stated direction, the scan may be repeated for other directions). The measurements may be made either with a goniophotometer or with a luminance meter. The patch luminance can be measured directly with a luminance meter or with the goniophotometer using an appropriate mask.

## 5.7 Photometric factors

Photometric factors are of three types:

- 1) measurement correction factors: These are applied to take into account measurement conditions, such as different ambient temperature and test position, and are employed when it is not possible to measure a light source in the laboratory according to clause 5.2. For lamps with nominal characteristics defined at temperatures other than 25 °C the correction factor shall be stated by the lamp manufacturer for a specified lamp/ballast combination.
- 2) service conversion factors: These apply when the service conditions differ from the test conditions according to clause 5.2. They are applied in the laboratory to allow for service conditions.
- 3) ballast lumen factor: This factor corrects for the effect of operating a luminaire with a ballast of different characteristics to those of the reference ballast and shall be quoted with all photometric data.

The ballast shall comply with the electrical performance requirements of the relevant IEC Publications. The ballast setting (lamp power delivered under reference conditions) shall be within  $\pm 5\%$  of the corresponding reference ballast and should be representative of the production ballast in setting and in power loss. If the ballast setting is outside these limits, a ballast lumen factor shall be introduced.

A reference ballast shall comply with its relevant IEC requirements

NOTE Ballast lumen factors are not relevant to luminaires employing self ballasted lamps.

## 5.8 Luminaires for test<sup>10)</sup>

The lamp(s) shall be measured and shall comply with its relevant IEC publication. If relevant publications do not exist, the lamp(s) shall comply as closely as possible with the nominal specifications of the lamp manufacturer.

When testing luminaires and bare lamps the ballasts built into the luminaire shall be used. If the luminaire under test does not have a built in ballast, the ballast type shall be of a type agreed by the luminaire manufacturer and the same ballast shall be used for testing the luminaire and the bare lamps.

The luminaire's specification shall be clearly and fully identified.

The luminaire shall be mounted according to the manufacturer's instructions. For surface mounted luminaires, the greater heat retention influence of a longer warm up compared to recessed or pendant mounted luminaires shall be taken into account by attaching the luminaire to a mounting board.

The board shall be approximately 15 mm thick and made of wood or wood fibre (or insulating material if required.) It shall be of the same outline as the plan view of the luminaire; minor corrugations of outline may be ignored. The lower surface of the board shall be smooth and shall be painted with a matt neutral grey non-metallic paint of a reflectance of  $50\% \pm 10\%$ . Boards for use in a photometric integrator shall be finished matt white on their upper surface and sides.

The position of the photometric centre of a luminaire shall be determined in accordance with the following and in accordance with Figure 5:

- 1) Luminaires with substantially opaque sides: At the centre of the main luminaire opening (or diffusing/prismatic member across the opening) if the lamp compartment is substantially white or luminous but at the lamp photometric centre if it is outside the plane of the opening, or if the lamp compartment is substantially black or non-luminous and there is no diffusing or prismatic member across the opening.
- 2) Luminaires with diffusing/prismatic sides: At the centre of the solid figure bounded in outline by the luminous surfaces but at the lamp photometric centre, if it is outside this solid figure.

---

<sup>10)</sup> See CIE 121, 5.3.1 and 5.3.2.

3) Luminaires with transparent sides or without side members: At the lamp photometric centre.

Luminaires other than those above shall have the definition of their photometric centre given in the publication of their data.

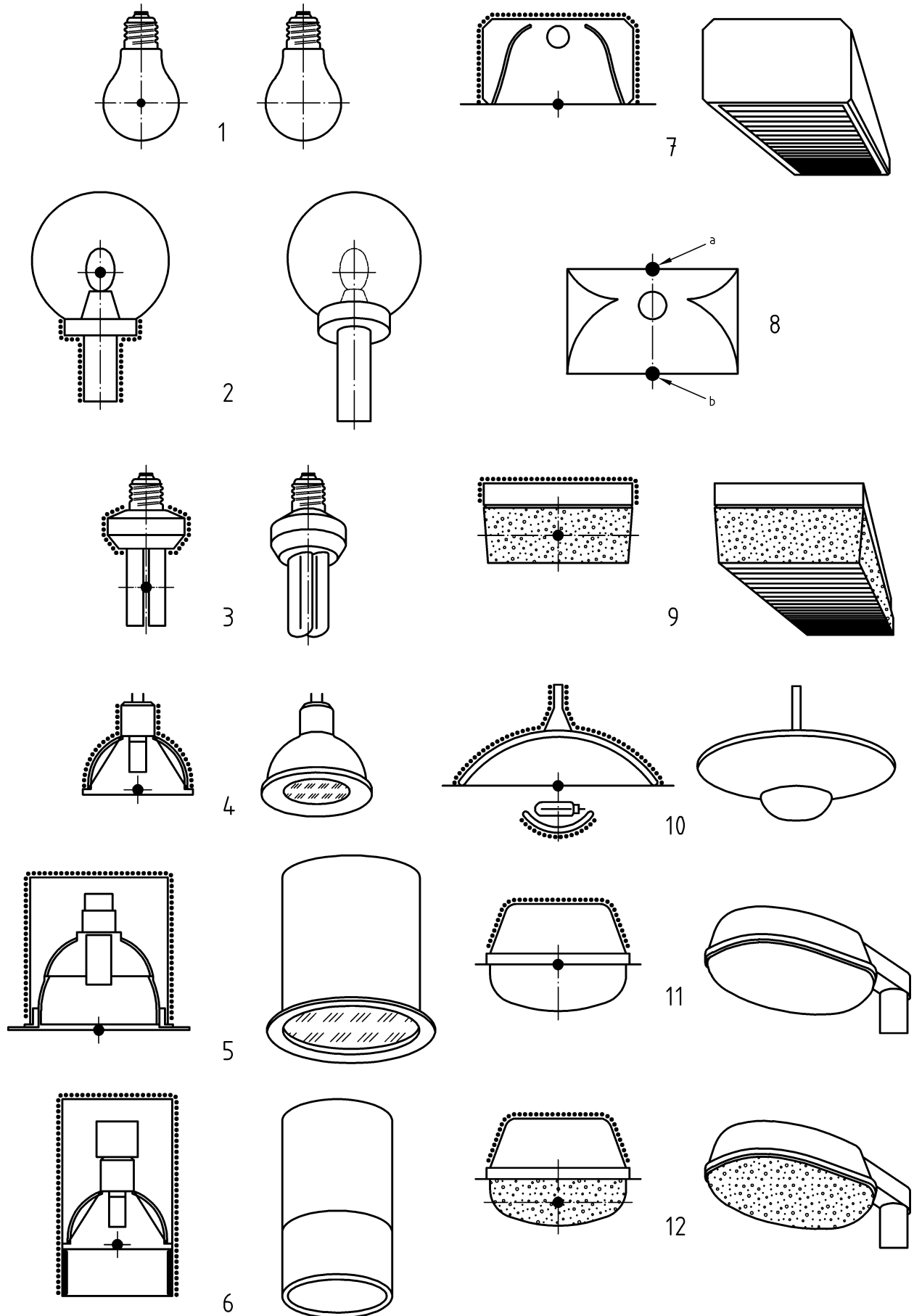

Figure 5 — Photometric centre of a luminaire

### Explanation of presentation

Presentation	Explanation
●	Photometric centre
—————	opaque, substantially black
/// /// ///	opaque, diffuse or specular reflectant
●●●●●●●●	translucent, clear
●●●●●●●●	compartment

### Photometric centre of light sources

- 1) Incandescent lamp
- 2) With a clear cover
- 3) Compact fluorescent lamp
- 4) Reflector lamp
- 5) Luminaire with reflecting mirror
- 6) Luminaire with shield, substantially black
- 7) Luminaire with opaque sides
- 8) Direct-indirect luminaire
  - a) Luminant area 1 with photometric centre 1
  - b) Luminant area 2 with photometric centre 2
- 9) Luminaire with diffusing/prismatic sides
- 10) Indirect luminaire with secondary reflector
- 11) Outdoor luminaire with clear cover
- 12) Outdoor luminaire with diffusing/prismatic cover

## 6 Requirements for measurement

### 6.1 General aspects

Basic photometric data of luminaires is produced by direct photometric measurements. To obtain reliable data a level of accuracy is necessary in all steps of data acquisition. This involves three different quantities:

- 1) measurement of photometric quantity (i.e., luminous intensity);
- 2) measurement of geometric quantities (e.g., angles of direction, photometric distances);
- 3) electrical measurements (e.g., voltages, current, power).

Measurements of luminous intensity distributions are usually made with goniophotometers. Usually one of two principles is used:

- a) photometric distance law (measurement of illuminance at a distance exceeding the limiting photometric distance);
- b) luminance integration (measurement of local luminance distribution on the luminaire's surface within the limiting photometric distance).

### **6.1.1 Goniophotometers**

#### **6.1.1.1 Goniophotometer type 1**

The light source is rotated around a vertical as well as a horizontal axis. The photometer head is fixed.

Measurements are possible only for light sources, which can be used in any orientation and whose relative luminous intensity distribution does not change with burning position.

Measurements of light sources with burning position dependent luminous flux are possible. If the operating orientation differs from the standard burning position, a correction of the measurement values is necessary. This can be determined with a auxiliary photometer, as long as its photometer head does not change direction and distance to the light source during movement, so that changes of the luminous flux by a change of burning position result in a proportional photo current.

NOTE 1 The ratio of the reference value and the photometer reading of the auxiliary photometer taken at the same time as a measured value may be used as a correction factor for the measured value. The reference value is the photometer reading of the auxiliary photometer, taken after the light source has been stabilized in its standards burning position.

NOTE 2 The partial luminous flux, which is used for correction, can be led to the auxiliary photometer through the end of a fibre optic, if the other end is completely reflecting and - without the usual protective coat - wound stably around the lamp.

The goniophotometers of type 1 can be distinguished as follows:

- 1) Type 1.1:
  - a) fixed horizontal axis, movable vertical axis;
  - b) measurement B-planes.
- 2) Type 1.2:
  - a) fixed vertical axis, movable horizontal axis;
  - b) measurement in B-planes.
- 3) Type 1.3:
  - a) fixed vertical axis, movable horizontal axis;
  - b) measurement in C-planes.

#### **6.1.1.2 Goniophotometer type 2**

The light source is rotated around a vertical axis and the photometer head is moved.

The goniophotometers of type 2 can be distinguished as follows:

- 1) Type 2.1:
  - a) fixed vertical axis, movable horizontal axis;

## EN 13032-1:2004 (E)

b) measurement in C-planes.

### 2) Type 2.2:

Light source and photometer head are situated on different ends of rotation axis.

### 3) Type 2.3:

moving of the photometer head on a straight line, (e.g. horizontal and/or vertical).

#### 6.1.1.3 Goniophotometer type 3

The light source is rotated around a vertical axis, a mirror arrangement around a horizontal axis. The photometer head is fixed.

The mirrors shall not limit the view of the light source from the photometer head and have to be plane. They should have a spectrally constant reflectance or their spectral reflectance shall be considered for the  $V(\lambda)$  correction of the used photometer head. Attention shall be paid to the polarization of the radiation due to reflection by the mirrors and the local situation of the reflection.

The goniophotometers of type 3 can be distinguished as follows:

#### 1) Type 3.1:

- a) centre of mirror in rotation centre;
- b) light source is rotated around the mirror on a fixed radius.

#### 2) Type 3.2:

- a) light source in rotation centre;
- b) the mirror is rotated around the light source on a fixed radius.

#### 3) Type 3.3:

light source and mirror are led on two oppositely orientated fixed radii around the rotation centre.

#### 6.1.1.4 Goniophotometer type 4

The light source is fixed and can be kept in any burning position.

The photometer head is moved on a virtual sphere, in whose centre point the centre of the light source is located.

The measurement of the light intensity distribution is usually performed by continuous movement in spherical zones (parallel to the equator) or in spherical segments (from pole to pole).

NOTE 1 In order to increase the measurement distance mirrors may be used, if the restrictions from 6.1.1.3 are considered.

NOTE 2 In order to shorten the time of measurement the number of photometer heads can be increased, so that the measurements can be done simultaneously on several paths.

### 6.1.2 Integrating photometers

#### 6.1.2.1 General

In an integrating photometer the luminous flux of the lamp to be measured is compared to the luminous flux of a standard lamp. As the theoretical requirements can only be approximately realized in practice measurement errors occur. These errors increase the more measuring sample and standard show differences regarding the following:



- 1) Dimensions;
- 2) spectral power distribution;
- 3) luminous intensity distribution;
- 4) absorption;
- 5) power consumption.

If an illuminance meter is used with the integrating photometer its characteristics shall fulfill the requirements of Table 3, without the calibration uncertainty. The characteristics, symbols and definitions shall be compliant to the requirements of Annex B.

#### **6.1.2.2 Influence of objects in the sphere**

All objects in the integrating sphere (e.g. screen, lamp holder and sockets) directly influence the measurement and thus shall be as small as possible; also the presence of the lamp influences the measurement.

Different object influences are to be recorded and corrected by additional measurements with an auxiliary lamp. This auxiliary lamp may be mounted close to the sphere surface opposite to the photometer head.

#### **6.1.2.3 Sphere paint**

The reflectance of the sphere paint shall be diffuse, spectral aselective and homogenous over the surface of the sphere. The sphere paint shall not be luminescent or fluorescent and shall have a reflectance between 0,75 and 0,85.

#### **6.1.2.4 Arrangement of lamp and screen**

The lamp shall be positioned close to the centre of the sphere. The screen is positioned in a way that the direct illumination of the photometer head is prevented.

NOTE The distance of the screen to the photometer head should be about 1/6 of the sphere diameter.

#### **6.1.2.5 Execution of measurement**

The comparison of luminous flux of the lamp to be measured and that of the standard lamp with similar dimensions should be done without any change in the arrangement of the screen and the photometer head. Deviations of the measured values due to the absorption of the lamp may be corrected by additional measurements with an auxiliary lamp equipment.

The luminous flux of the lamp can be calculated according to formula (1).

$$\Phi = \Phi_N \times \frac{Y}{Y_N} \times \frac{Y_{HN}}{Y_H} \quad (1)$$

where

$\Phi$  is the luminous flux of the lamp to be measured;

$\Phi_N$  is the luminous flux of the standard lamp;

$Y$  is the reading of the lamp to be measured;

$Y_N$  is the reading of the standard lamp;

$Y_H$  is the reading of the auxiliary lamp with built in lamp to be measured (not in operation);

$Y_{HN}$  is the reading of the auxiliary lamp with built in standard lamp (not in operation).

The influence of temperature changes within the sphere to the lamps and photometer head shall be taken into account.

NOTE 1 It is not possible to correct measurement deviations due to different intensity distributions of the lamp to be measured and the standard lamp by the use of the auxiliary lamp.

NOTE 2 It is an advantage to select the order of measurement in such a way that the auxiliary lamp has to be operated only once. In case of same type and dimensions of the lamp to be measured and the standard lamp the measurements with the auxiliary lamp are not necessary.

NOTE 3 The described measurement procedure can be simplified (no auxiliary lamp measurement necessary) if the measurement errors are small, known or can be neglected.

NOTE 4 Guidance of construction and use of an integrating sphere are given in CIE 84.

### 6.1.3 Illuminance meters<sup>11)</sup>

Illuminance meters used in conjunction with goniophotometers or integrators in the laboratory shall meet the requirements as specified in Table 3.<sup>12)</sup>

Values in Table 3 shall be provided by the manufacturer. If significant variation is observed at recalibration, spectral responsivity and linearity shall be checked.

---

<sup>11)</sup> For a detailed description of characterizing illuminance meters, as well as methods to determine their characteristics, see annex B.

<sup>12)</sup> See CIE 121, 4.4.1.

**Table 3 — Characteristics for illuminance meters**

Characteristic	Symbol <sup>1)</sup>	Maximal Value
Calibration uncertainty	$u_{\text{cal}}$ <sup>2)</sup>	1 %
V( $\lambda$ ) match	$f_1'$	1,5 %
UV response	$u$	0,2 %
IR response	$r$	0,2 %
Cosine response	$f_2$ <sup>3)</sup>	1,5 %
Linearity	$f_3$	0,2 %
Display unit	$f_4$	0,2 %
Fatigue	$f_5$	0,1 %
Temperature dependence	$f_6$ <sup>4)</sup>	0,2 %
Modulated light	$f_7$ <sup>5)</sup>	0,1 %
	$f_7(f_u)$ <sup>6)</sup>	5 %
	$f_7(f_o)$ <sup>7)</sup>	5 %
Spatial response	$f_9$	15 %
Range change	$f_{11}$	0,1 %
Total characteristic	$f_{\text{total}}$	4 %
Calculation of the total characteristic	$f_{\text{total}} = u_{\text{cal}} + f_1' + u + r + f_2 + f_3 + f_4 + f_5 + f_6 + f_7 + f_{11}$	

- <sup>1)</sup> The characteristics in the shaded fields are used for the calculation of the total characteristic.
- <sup>2)</sup>  $u_{\text{cal}}$  the expanded measurement uncertainty for the calibration of the photometer combined from the transfer uncertainty and the uncertainty of the standard for a confidence level of about 95 % ( $k = 2$ ).
- <sup>3)</sup> The maximum value shall not be fulfilled for measurements with perpendicular light incidence. In this case the value  $f_2 = 0$  shall be used for the calculation of the total characteristic. The maximum value for the total characteristic is reduced to 3 %.
- <sup>4)</sup> With temperature  $T = 25$  °C and temperature difference  $\Delta T = 2$  °C.
- <sup>5)</sup> measured at 100 Hz  
For measurement on pulsed light sources with small duty cycles a sufficient overload protection of the photometer is required.
- <sup>6)</sup> limit frequency  $f_u = 40$  Hz
- <sup>7)</sup> limit frequency  $f_o = 10^5$  Hz

### 6.1.4 Luminance meters

Luminance meters used in conjunction with integrators or goniophotometers in the laboratory shall meet the requirements specified in Table 4.

Values in Table 4 shall be provided by the manufacturer. If significant variation is observed at recalibration, spectral responsivity and linearity shall be checked.

**Table 4 — Characteristics for luminance meters**

Characteristic	Symbol 1)	Maximal Value
Calibration uncertainty	$u_{cal}$ 2)	1,5 %
$V(\lambda)$ match	$f_1'$	2 %
UV response	$u$	0,2 %
IR response	$r$	0,2 %
Directional response	$f_2$ (g)	2 %
Surrounding field	$f_2$ (u)	1 %
Linearity	$f_3$	0,2 %
Display unit	$f_4$	0,2 %
Fatigue	$f_5$	0,1
Temperature dependence	$f_6$ 3)	0,2 %
Modulated light	$f_7$ 4)	0,1 %
	$f_7$ ( $f_U$ ) 5)	5 %
	$f_7$ ( $f_O$ ) 6)	5 %
Polarization	$f_8$	0,2 %
Range change	$f_{11}$	0,1 %
Focusing distance	$f_{12}$	0,4 %
Total characteristic	$f_{total}$	5 %
Calculation of the total characteristic	$f_{total} = u_{cal} + f_1' + u + r + f_2$ (g) + $f_2$ (u) + $f_3 + f_4 + f_5 + f_6 + f_7 + f_8 + f_{11} + f_{12}$	
1) The characteristics in the shaded fields are used for the calculation of the total error characteristic. 2) $u_{cal}$ the expanded measurement uncertainty for the calibration of the photometer combined from the transfer uncertainty and the uncertainty of the standard for a confidence level of about 95 % ( $k = 2$ ). 3) With temperature $T = 25$ °C and temperature difference $\Delta T = 2$ °C. 4) measured at 100 Hz For measurement on pulsed light sources with small duty cycles a sufficient overload protection of the photometer is required. 5) limit frequency $f_U = 40$ Hz 6) limit frequency $f_O = 10^5$ Hz		

## 6.2 Measurement uncertainties

All goniophotometers require certain characteristics to provide low measurement uncertainties as follows:

- 1) the resolution of the angular measurement shall be 0,1° or less;
- 2) the angular deviation for the correlation of the luminaire axes to the rotation axes shall be 0.5° or less in all measurement positions;
- 3) for luminous intensity measurements according to the inverse square law the measurement distance shall be at least 5 times the maximum dimension of the luminaire light emitting area. However, for luminaires with distributions significantly different from a cosine the above ratio will give rise to errors in excess of 1 %. For such luminaires a measurement distance ratio in excess of 10 : 1 may be needed.

NOTE The minimum measuring distance for a floodlight is a function of the focal length  $f$  of the reflector, the radius  $a$  of the reflector aperture and the diameter  $s$  of the smallest element of the light source (arc stream or filament).

The point at this minimum distance is called the "beam cross over" point and is the location where the optic is seen to be completely flashed.

Only at distances greater than this does the inverse-square law apply.

The distance  $D_{\min}$  to the "beam cross-over" point can be calculated by the formula (2).

$$D_{\min} = \frac{a^2}{4f} \left( 1 + \frac{2a}{s} \right) + \frac{2af}{s} \quad (2)$$

Explanation see Figure 6.

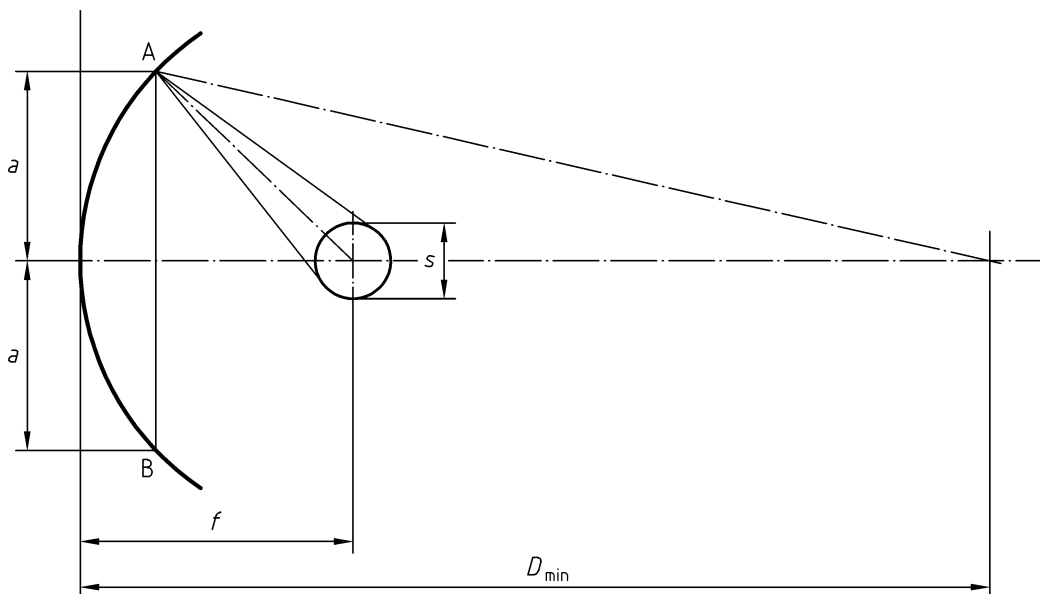

**Figure 6 — Determination of minimum measurement distance for floodlights**

Additionally:

- 1) goniophotometers type 1 require that the influence of temperature through position changing or luminaire movement shall be compensated by an auxiliary detector or other means;

- 2) goniophotometers type 2 require where necessary and practicable, compensation of the angle of incidence different from the normal incidence angle shall be made, see B.4.1;
- 3) goniophotometers Type 3 require that the mirrors shall be tested for variations in reflectance and flatness, (see annex C) and that the spectral influence of mirror shall not reduce the accuracy specified for the photometer.

## **7 Basic data format requirements**

A traceable path to photometric test records and measuring equipment shall be provided by inclusion of the test report numbers with all declared data. These records shall be made available upon request.

All data shall be presented clearly and unambiguously.

The ballast and lamp type and references shall be given with all declared data.

## **8 Electronic transfer of luminaire data**

### **8.1 General**

The CEN file format given in Annex D consists of two major sections. The first section comprises two parts, part 1 contains general information about the luminaire and part 2 a list of specific code names concerning the physical properties of the luminaire.

The second section can be appended to the file containing the first section, or it can be provided as a separate file. It is divided into three parts. General information can be given in the first part, while the second part includes a set of specific code names concerning the measurement. The luminous intensity distribution data makes up the third part.

NOTE This European Standard describes a luminaire file format which is a slightly changed version of the international file format described in CIE 102:1993.

### **8.2 File format**

The file is composed of two different line types: structured lines (lines beginning with a specific code name) and unstructured lines (label lines and data lines). Structured lines can be of two types, key lines (which shall be included) and information lines (which can be left out).

Certain key lines are used to separate different parts of the file.

After CENF=, CENA= and PHOT=INCLUDE there may be a group of label lines which are not structured and can carry any information.

Label lines may contain descriptive text about the luminaire, the lamp(s) used, and other notes or comments. Each line can be a maximum of 78 characters in length. Totally blank lines are permitted. The program reading the file recognizes the end of the label lines when it receives the next key line. The number of label lines is limited to sixty in each section.

Data lines are used in the user defined sections. They are unstructured lines with a maximum of 78 characters.

Specific codes prefixing structured lines utilize five character names, which shall be upper case alpha-numeric characters with the last character "=".

It is not necessary to include each and every structured line in each file, however all key lines shall be included even if no data follows the structured name. It is permissible to include any number of lower case letters including spaces, which expand the five-character names into better defined names and make the file more understandable. The application program reading the names shall be capable of discerning and ignoring the lower case letters.

The complete file format specification is shown in annex D.

## **Annex A** **(informative)**

### **Screening against stray light**

Stray light is any light which reaches the photometer head other than directly from the source to be measured, due to reflections or to other light sources.

The photometer head should be screened so that as far as possible it sees only the luminaire and, where appropriate, the lower surface of the mounting board. Where a mirror is used the photometer head should be screened to see only the image of the luminaire and so as not to receive light directly from any part of the luminaire itself.

All surfaces, other than the luminaire (or the mirror), that are seen by the photometer head should be finished matt black, including the bevelled edges of mirrors.

It should be noted that many 'matt' black paints have a luminance factor near the normal to the surface as high as 4 % and higher at glancing angles of incidence.

**NOTE** Screens should be arranged so that stray light from the luminaire only reaches the photometer head after two or more reflections. Where this is not possible surfaces should be covered with e. g. black velvet, black carpet. Any surface such as the edges of screens which are parallel with the photometer head/luminaire axis, should be grooved, angled or chamfered to a sharp edge to minimise reflections onto the photometer head.

The background of the luminaire which can be viewed by the photometer head should be matt black. This may include the floor and ceiling. The remainder of the room may be lighter coloured provided that precautions have been taken to eliminate stray light.

Possible paths of stray light which should not be overlooked are:

- 1) luminaire - blackened surface (e. g. floor, screen) - mirror - photometer head;
- 2) luminaire - blackened surface (e. g. floor, screen) - luminaire - mirror - photometer head;
- 3) luminaire - mirror - luminaire - mirror - photometer head.

Stray light that cannot be eliminated should be subtracted from the readings taking into account the variation of stray light with luminaire position.

The amount of resultant stray light can be difficult to measure. For example, any screen placed for such a measurement between the luminaire and the photometer head can also screen a path of stray light via the mirror to the photometer head.

## Annex B (normative)

### Properties of photometers

#### B.1 Deviation of relative spectral responsivity from the $V(\lambda)$ function

The degree to which the relative spectral responsivity  $s_{\text{rel}}(\lambda)$  matches the spectral luminous efficiency  $V(\lambda)$  of the human eye for photopic vision can be characterized by means of the characteristic  $f_1'$  where:

$$f_1' = \frac{\int_0^{\infty} |s_{\text{rel}}^*(\lambda) - V(\lambda)| d\lambda}{\int_0^{\infty} V(\lambda) d\lambda} \quad (\text{B.1})$$

$$s_{\text{rel}}^*(\lambda) = s_{\text{rel}}(\lambda) \times \frac{\int_0^{\infty} S_A(\lambda) \times V(\lambda) d\lambda}{\int_0^{\infty} S_A(\lambda) \times s_{\text{rel}}(\lambda) d\lambda} \quad (\text{B.2})$$

where

$s_{\text{rel}}^*(\lambda)$  is the normalized relative spectral responsivity;

$S_A(\lambda)$  is the spectral distribution of the illuminant used in the calibration;

$s_{\text{rel}}(\lambda)$  is the relative spectral responsivity with arbitrary reference;

$V(\lambda)$  is the spectral luminous efficiency of the human eye for photopic vision.

#### B.2 UV response $u$

##### B.2.1 Definition

The UV response  $u$  of a photometer head is the ratio of the signal  $Y(UV)$ , when the head is irradiated by a defined UV source combined with a specified UV filter, to the signal  $Y$  when it is irradiated by the same source without the filter:

$$u = \left| \frac{Y_{UV}}{Y} - u_0 \right| \quad (\text{B.3})$$

where according to equation (B.4)  $u_0$  is:



$$u_0 = \frac{\int_0^{\infty} S_{UV}(\lambda) \times \tau(\lambda) \times V(\lambda) d\lambda}{\int_0^{\infty} S_{UV}(\lambda) \times V(\lambda) d\lambda} \quad (\text{B.4})$$

where

$\tau(\lambda)$  is the spectral transmission of the filter for determination of UV response;

$S_{UV}(\lambda)$  is the spectral distribution of the lamp for determination of UV response.

### B.2.2 Measurement

The UV response shall be measured by irradiating the photometer head with a lamp having a spectral distribution of the type shown in Figure B.1. The UV filter used shall have the spectral transmission shown in Figure B.2. The filter and any auxiliary optics (not part of the luminance meter) shall not fluoresce. The irradiation of the photometer head without the filter should cause a signal at least 1 000 times as large as the smallest resolvable signal.

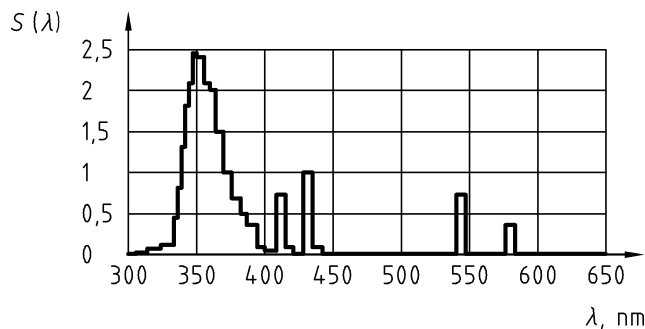

**Figure B.1 — Spectral distribution of a lamp for determination of the UV response  $u$**

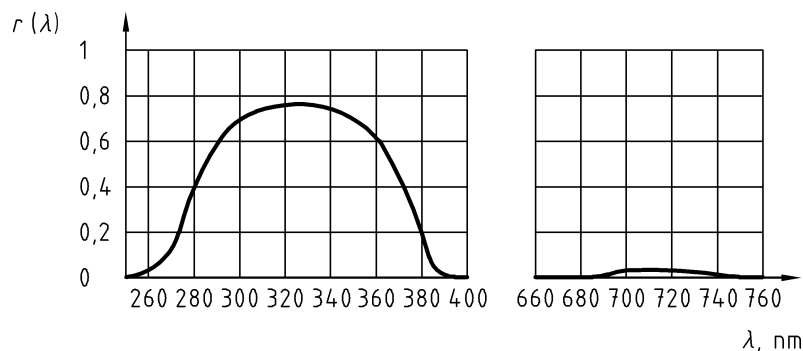

**Figure B.2 — Spectral transmittance  $\tau(\lambda)$  of UV filter for the determination of the UV response  $u$**

### B.2.3 Characterization

The UV response  $u$  shall be stated on the data sheet.

### B.3 IR Response $r$

#### B.3.1 Definition

The IR response  $r$  of a photometer head is the ratio of the signal  $Y(IR)$ , when the head is irradiated by a tungsten-halogen lamp set for illuminant A and combined with a specified IR filter, to the signal  $Y$  when it is irradiated by the same source without the IR filter:

$$r = \left| \frac{Y_{IR}}{Y} - r_0 \right| \tag{B.5}$$

where according to equation (B.6)  $r_0$  is:

$$r_0 = \frac{\int_0^{\infty} S_{IR}(\lambda) \times \tau(\lambda) \times V(\lambda) d\lambda}{\int_0^{\infty} S_{IR}(\lambda) \times V(\lambda) d\lambda} \tag{B.6}$$

where

$\tau(\lambda)$  is the spectral transmittance of the filter for determination of IR response;

$S_{IR}(\lambda)$  is the spectral distribution of the lamp for determination of IR response.

#### B.3.2 Measurement

The IR response shall be measured by irradiating the photometer head with a tungsten-halogen lamp set for illuminant A and combined with an IR filter whose spectral transmission is shown in Figure B.3. The irradiation of the photometer head without the filter shall cause a signal at least 1 000 times as large as the smallest resolvable signal.

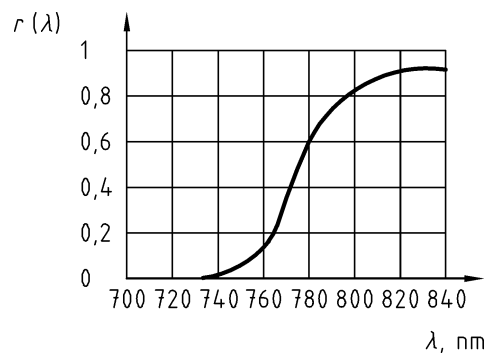

Figure B.3 — Spectral transmittance  $\tau(\lambda)$  of IR filter for the determination of the IR response  $r$

#### B.3.3 Characterization

The IR response  $r$  shall be stated on the data sheet.

## B.4 Directional response

### B.4.1 Directional response for the measurement of illuminance

#### B.4.1.1 Description

The effect of light incident on the acceptance area of the photometer head depends on the angle of incidence. The directional response function (evaluation of the incident light as a function of the angle of incidence) is determined by the form and the optical construction of the photometer head.

By equipping the photometer head with directionally selective optical elements (e.g. diffusing adaptors of various shapes, special optical components) special evaluation functions can be realized. These include cosine adaptors for the measurement of illuminance,  $E_o$  adaptors for the measurement of spherical illuminance,  $E_z$  adaptors for the measurement of semi-cylindrical illuminance.

#### B.4.1.2 Measurement

For the measurement of directional response a small light source shall be set up at a distance corresponding to at least 20 times the largest dimension of either the light source or the acceptance area of the photometer head.

Special precautions shall be taken to exclude stray light from the acceptance area of the photometer head. Rotation of the photometer head around a horizontal or vertical axis varies the angle of incidence referred to the centre of the acceptance area of the photometer head. The centre of revolution shall coincide with the centre of the acceptance area or any described point marked by the manufacturer. Measurements of the signal as a function of the angle of incidence shall be carried out in at least two mutually perpendicular planes.

**NOTE** For photometer heads with a nonlinear relationship between input quantity and signal output, the measurement should be conducted at a constant signal level or the result should be corrected via the measured input-output characteristic of the photometer head. In the first case the illuminance should be changed in a defined way (e.g., change of distance).

#### B.4.1.3 Illuminance E

For a photometer head in an illuminance meter, the deviation in the directional response to the incident radiation is characterized by  $f_2(\varepsilon, \varphi)$ :

$$f_2(\varepsilon, \varphi) = \frac{Y(\varepsilon, \varphi)}{Y(0, \varphi) \times \cos \varepsilon} - 1 \quad (\text{B.7})$$

where

$Y(\varepsilon, \varphi)$  is the signal output as a function of the angle of incidence;

$\varepsilon$  is measured with respect to the normal to the measuring plane or optical axis;

$\varphi$  is the Azimuth angle.

For characterizing the directional response error by a single factor the characteristic  $f_2$  is used:

$$f_2 = \int_0^{85^\circ} \int_{180^\circ}^{\pi} |f_2(\varepsilon)| \times \sin 2\varepsilon \, d\varepsilon \quad (\text{B.8})$$

**NOTE** This equation implies cylindrical symmetry.

**B.4.1.4 Spherical illuminance  $E_0$**

For a photometer head in a spherical illuminance meter, the deviation in directional response is characterized by:

$$f_{2,0}(\varepsilon, \varphi) = \frac{Y(\varepsilon, \varphi)}{Y(0,0)} - 1 \tag{B.9}$$

For characterizing the directional evaluation by a single factor the characteristic  $f_{2,0}$  is used:

$$f_{2,0} = \frac{1}{2} \times \int_0^\pi |f_{2,0}(\varepsilon, 0)| \times \sin \varepsilon \, d\varepsilon \tag{B.10}$$

**B.4.1.5 Cylindrical illuminance  $E_z$**

For a photometer head to be used for the measurement of the cylindrical illuminance, the deviation in directional response is characterized by:

$$f_{2,z}(\varepsilon, \varphi) = \frac{Y(\varepsilon, \varphi)}{Y\left(\frac{\pi}{2}, 0\right) \times \sin \varepsilon} - 1 \tag{B.11}$$

NOTE It is advisable to give the function defined in equation separately for the horizontal  $\varepsilon = \pi/2$  and vertical  $\varphi = 0$  planes.

In the vertical plane:

$$f_{2,z}(\varepsilon, 0) = \frac{Y(\varepsilon, 0)}{Y\left(\frac{\pi}{2}, 0\right) \times \sin \varepsilon} - 1 \tag{B.12}$$

In the horizontal plane:

$$f_{2,z}(0, \varphi) = \frac{Y\left(\frac{\pi}{2}, \varphi\right)}{Y\left(\frac{\pi}{2}, 0\right)} - 1 \tag{B.13}$$

For characterizing the directional response deviation by a single value, the characteristic  $f_{2,z}$  is used:

$$f_{2,z} = \frac{1}{\pi} \int_{5^\circ - \frac{\pi}{180^\circ}}^{175^\circ - \frac{\pi}{180^\circ}} |f_{2,z}(\varepsilon, 0)| \times \sin^2 \varepsilon \, d\varepsilon + \frac{1}{2\pi} \int_0^{2\pi} \left| f_{2,z}\left(\frac{\pi}{2}, \varphi\right) \right| \, d\varphi \tag{B.14}$$

**B.4.1.6 Semi-cylindrical illuminance  $E_{sz}$**

For a photometer head to be used for the measurement of the semi-cylindrical illuminance  $E_{sz}$ , the deviation in the directional response is characterized by:

$$f_{2,sz}(\varepsilon, \varphi) = \frac{Y(\varepsilon, \varphi)}{Y\left(\frac{\pi}{2}, 0\right) \times \cos \varepsilon \times (1 + \cos \varphi)} - 1 \quad (\text{B.15})$$

NOTE It is advisable to give the function for the directional response separately for the horizontal  $\varepsilon = \pi/2$  and the vertical  $\varepsilon = 0$  planes.

In the vertical plane:

$$f_{2,sz}(\varepsilon, 0) = \frac{Y(\varepsilon, 0)}{Y\left(\frac{\pi}{2}, 0\right) \times \sin \varepsilon} \quad (\text{B.16})$$

For the horizontal plane:

$$f_{2,sz}\left(\frac{\pi}{2}, \varphi\right) = \frac{Y\left(\frac{\pi}{2}, \varphi\right)}{Y\left(\frac{\pi}{2}, 0\right) \times (1 + \cos \varphi)} - 1 \quad (\text{B.17})$$

For characterizing the directional response deviations by a single value the characteristic  $f_{2,sz}$  is used:

$$f_{2,sz} = \frac{1}{\pi} \int_{5^{\circ} \frac{\pi}{180^{\circ}}}^{175^{\circ} \frac{\pi}{180^{\circ}}} f_{2,sz}(\varepsilon, 0) \times \sin^2 \varepsilon \, d\varepsilon + \frac{1}{2\pi} \int_{-175^{\circ} \frac{\pi}{180^{\circ}}}^{175^{\circ} \frac{\pi}{180^{\circ}}} f_{2,sz}\left(\frac{\pi}{2}, \varphi\right) \times (1 + \cos \varphi) \, d\varphi \quad (\text{B.18})$$

It is recommended that the two components in equation (B.18) are given separately.

## B.4.2 Directional response for the measurement of luminance

### B.4.2.1 Description

Luminance meters shall evaluate the luminance of the assessed surface, within a measurement field of uniform responsivity. Luminous areas outside the measurement field shall not influence the measurement results. The directional response function can be used to describe the directionally dependent evaluation and the influence of the surrounding luminance outside the measurement field. The response to incident light on the acceptance area of the photometer head is a function of the incidence angle. The directional response function (evaluation of the incident light as a function of the angle of incidence) is determined by the geometrical optics, construction of the photometer head and stray light in the optical system. Special directional response functions can be generated by fitting the photometer head with special lenses or other such accessories (e.g., interchangeable objectives). One example is for the measurement of the equivalent veiling luminance.

### B.4.2.2 Measurement of directional response

In order to measure the directional response function, a light source shall be positioned at a sufficiently large distance from the acceptance area. The extent of the luminous area of the source shall not be greater than 5 % of the measurement field angle. Focusing luminance meters shall be focused on the light source. The measurement shall be carried out at a distance of 10 m for non-focusing luminance meters or at a distance recommended by the manufacturer. The luminance meter shall be rotated around the centre of the entrance pupil. As an alternative technique, the light is moved perpendicularly to the optical axis of the photometer head, keeping the photometer head fixed. The measurement of the output signal as a function of the angle of incidence shall be obtained in at least four equally spaced directions. Stray light shall be prevented from falling on the acceptance area.

**B.4.2.3 Characterization**

The directional response of luminance meters is characterized by the directional response function  $f_2(\varepsilon, \varphi)$ :

$$f_2(\varepsilon, \varphi) = \frac{Y(\varepsilon, \varphi)}{Y(0, \varphi)} \tag{B.19}$$

where

$Y(\varepsilon, \varphi)$  is the output signal at angle of incidence  $\varepsilon, \varphi$  (Figure B.4);

$Y(0, \varphi)$  is the output signal for light incident in the direction of the optical axis of the photometer head.

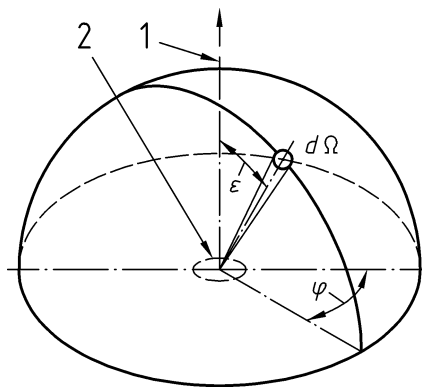

**Key**

- 1 Optical axis
- 2 Entrance pupil
- $\varepsilon$  = Angle of incidence, measured from the optical axis
- $\varphi$  = Azimuth angle.

**Figure B.4 — Coordinates for the definition of the function  $f_2(\varepsilon, \varphi)$**

For an abbreviated characterization of the directional response function  $f_2(\varepsilon, \varphi)$  the following shall be given:

- 1) measurement field angle  $\alpha$ ;
- 2) uniformity characteristics  $f_{2,g}$ .

In addition, the following shall be specified:

- 3) characteristics  $\overline{f_2(\varepsilon_{,9/10})}$ ;
- 4) characteristics  $\overline{f_2(\varepsilon_{1/100})}$ ;
- 5) characteristics  $\overline{f_2(\varepsilon_{1/100}, \varphi)}$  for characterizing the spatial symmetry.

The uniformity characteristic  $f_{2,g}$  is defined as:

$$f_{2,g} = 1 - \frac{Y_{\min}}{Y_{\max}} \tag{B.20}$$

where

$Y_{\min}$  is the smallest output signal for an angle of incidence within 90 % of the measurement field using the measurement arrangement given in B.4.2.2;

$Y_{\max}$  is the largest output signal for an angle of incidence within 90 % of the measurement field using the measurement arrangement given in B.4.2.2.

The characteristics  $f_2(\varepsilon_{9/10})$  and  $f_2(\varepsilon_{1/100})$  are defined as:

$$f_2(\varepsilon_{9/10}) = 1 - \frac{\bar{\varepsilon}_{9/10}}{\bar{\varepsilon}_{1/100}} \quad (\text{B.21})$$

$$f_2(\varepsilon_{1/100}) = 1 - \frac{\bar{\varepsilon}_{1/10}}{\bar{\varepsilon}_{1/100}} \quad (\text{B.22})$$

where

$\bar{\varepsilon}_{9/10}$  is the average angle within which the output is equal to or greater than 0,9 times the value of the incident light in the direction of the optical axis;

$\bar{\varepsilon}_{1/10}$  is the average ten-percent measurement angle;

$\bar{\varepsilon}_{1/100}$  is the average one-percent measurement angle.

These values are the average of at least four equally separated plane measurements.

The directional symmetry of the measurement is characterized by the characteristic  $f_{2,s}$ :

$$f_{2,s} = \frac{Y_{\max}(\bar{\varepsilon}_{1/10}, \varphi_1) - Y_{\min}(\bar{\varepsilon}_{1/10}, \varphi_2)}{Y_{\max}(\bar{\varepsilon}_{1/10}, \varphi_1) + Y_{\min}(\bar{\varepsilon}_{1/10}, \varphi_2)} \quad (\text{B.23})$$

where

$Y_{\max}$  is the maximum output signal at  $\bar{\varepsilon}_{1/10}$  ;

$Y_{\min}$  is the minimum output signal at  $\bar{\varepsilon}_{1/10}$  ;

$\varphi_1$  is the angle for output  $Y_{\max}$  ;

$\varphi_2$  is the angle for output  $Y_{\min}$  ;

$\bar{\varepsilon}_{1/10}$  is the average value of the ten-percent measurement angle.

The corresponding values should also be given for the hundredth angle.

#### **B4.2.4 Measurement of the effect of the surrounding field**

For the measurement of the effect of the surrounding luminance (veiling glare), an illumination arrangement is necessary. A uniform luminous surface (in the direction of the entrance pupil) at least ten times as large as the measurement field shall be used. The luminance of this surface (surrounding) shall be set such that it is at least ten times the maximum signal on the most sensitive output range.

A gloss trap ("black" surface of negligibly small luminance) shall be fitted as an alternative to the luminous surface. This shall exceed the dimensions of the measurement field in the image plane by 10 % (Figure B.5). Measurements shall be made with and without the gloss trap.

The characterization of the effect of the surrounding luminance is given by the function  $f_2(u)$ :

$$f_{2,u} = \frac{Y_{\text{surround}}}{Y_{\text{Total}} - Y_{\text{surround}}} \tag{B.24}$$

where

$Y_{\text{surround}}$  is the output signal for measurement with the gloss trap (black field);

$Y_{\text{Total}}$  is the output signal for measurement with both bright surround and measurement field.

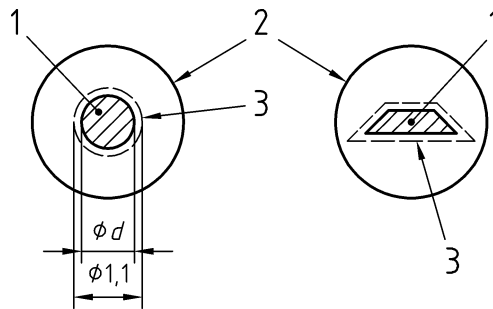

**Key**

- 1 Measurement field
- 2 Field of view
- 3 Gloss trap

**Figure B.5 — Diagram showing the size of the gloss trap in determining  $f_2(u)$**

The characterization of the directional response function for the measurement of the equivalent veiling luminance  $L_s$  (luminance meters with supplementary optics) is given by the spatial response function  $f_2(\varepsilon, \varphi)$ :

$$f_2(\varepsilon, \varphi) = \frac{Y(\varepsilon, \varphi)}{Y(0, \varphi)} \tag{B.25}$$

## B.5 Polarization dependence

### B.5.1 Description

The output signal of a photometer can depend on the polarization conditions of the measured light. In this case, the output signal  $Y$  changes when the linearly polarized quasiparallel incident light is rotated around the direction of incidence.

### B.5.2 Measurement

In order to measure the polarization dependence, unpolarized light from a point source, incident along the optical axis, is required following the measurement arrangement described in B.4.2.2.

NOTE 1 The light from a filament source is generally polarized. Depolarization can be achieved by placing a glass plate, slightly tilted, in front of the light source. The position of the glass plate, in order to achieve complete depolarization, is determined with the aid of a polarization-independent detector (e.g., a windowless silicon planar photodiode perpendicular to the incident light) placed behind a polarization filter. To achieve complete polarization of the radiation (including the tilted glass plate), a polarizer (e.g., two sheet polarizers placed back-to-back with their axes parallel) is placed in front of the light source. The polarizer can be rotated around the direction of incidence in order to change the position of the plane of polarization.



NOTE 2 To determine whether the first polarizer is completely polarizing the transmitted light, a second polarizer (analyzer) is used. After ascertaining complete polarization of the incident radiation, the second polarizer is removed. The maximum ( $Y_{\max}$ ) and minimum ( $Y_{\min}$ ) output signals of the photometer are then measured while rotating the first polarizer.

### B.5.3 Characterization

To characterize the sensitivity of the photometer to polarized light the function  $f_8(\varepsilon, \varphi)$  is given by:

$$f_8(\varepsilon, \varphi) = \frac{Y_{\max}(\varepsilon, \varphi) - Y_{\min}(\varepsilon, \varphi)}{Y_{\max}(\varepsilon, \varphi) + Y_{\min}(\varepsilon, \varphi)} \quad (\text{B.26})$$

where

$Y_{\max}$  maximum output signal;

$Y_{\min}$  minimum output signal.

To characterize the polarization dependence of a photometer head by a single value, the characteristics  $f_8$  shall be determined under the following geometrical conditions:

- a) Illuminance: angle of incidence  $\varepsilon = 30^\circ$ ,  $\varphi = 0^\circ$ ;
- b) Spherical illuminance: angle of incidence  $\varphi = 0^\circ$ ;
- c) Cylindrical illuminance and semi-cylindrical illuminance: angle of incidence  $\varepsilon = 60^\circ$ ,  $\varphi = 30^\circ$ ;
- d) Luminance: angle of incidence  $\varepsilon = 0^\circ$ .

## B.6 Effect of non-uniform illumination of the acceptance area of a photometer head

### B.6.1 Description

The construction of some photometer heads can lead to a significant dependence of the responsivity (including the relative spectral responsivity) on the incident-light position in the acceptance area. This dependence disappears when the aperture is uniformly illuminated.

### B.6.2 Measurement

For this measurement, a light source is arranged as described in B.4.1.2 and B.4.2.2. A circular aperture 1/10 the size of the acceptance area is placed in front of the acceptance area of the photometer head. Stray light shall be prevented from falling on the photometer head.

The circular aperture is placed in each of five positions in front of the entrance aperture as follows:

- a) Position 1: centre of clear opening of the circular aperture in front of and over the middle of the entrance aperture.
- b) Positions 2 to 5: centre of clear opening of the circular aperture placed in front of a point which is 2/3 along the radius from the centre of the entrance aperture. The four positions (2 to 5) are at  $90^\circ$  intervals around the centre of the entrance aperture.

### B.6.3 Characterization

To characterize the non-uniform illumination of the acceptance area, the characteristic  $f_9$  is given by:

$$f_9 = \frac{\sum_{i=2}^5 |Y_i - Y_1|}{4 \times Y_1} \quad (\text{B.27})$$

where

$Y_i$  is the output signal from the initial illumination value  $X$ , at each of the four points 2 to 5 in the plane of the entrance aperture of the photometer head;

$Y_1$  is the output signal from the same initial illumination value  $X$ , at the centre of the entrance aperture.

## **B.7 Influence of a change in focusing distance**

### **B.7.1 Description**

Luminance meters, with a focusing photometer head focused on a constant luminance in the measurement field, can change their output signal with a change of object distance.

### **B.7.2 Measurement**

In order to measure the influence of a change in focusing distance, a luminance standard is utilized whose luminous surface is larger than the measurement field and the acceptance area of the photometer head. The luminous standard is positioned at a short distance ( $\approx 10$  cm) in front of the entrance aperture. The luminance of the luminance standard is set at a level that results in an output signal approximately 90 % of the full-scale reading on an arbitrary range. The output signals are measured by focusing the photometer head at the largest and then at the smallest focusing distance specified by the manufacturer.

### **B.7.3 Characterization**

The effect of a change in the focusing distance is characterized by the characteristic  $f_{12}$  :

$$f_{12} = \frac{Y_1}{Y_2} - 1 \quad (\text{B.28})$$

where

$Y_1$  is the output signal, focused at the shortest distance;

$Y_2$  is the output signal, focused at the longest distance.

## **B.8 Linearity of the detector**

### **B.8.1 Definition**

Linearity of a detector is the property whereby the output quantity of the detector is proportional to the input quantity, that is, the responsivity is constant over a specified range of inputs.

**NOTE 1** A detector is usually linear only over a certain range of input levels. Outside this range it can become nonlinear. The range should be stated.

**NOTE 2** The linearity range of a detector can be affected by the use of unsuitable electronic circuitry.

### B.8.2 Measurement

The most accurate method for measuring the linearity of radiometers uses the principle of additivity of radiant fluxes by the technique of multiple sources or apertures.

### B.8.3 Characterization

The characterization of the linearity deviation of photometers is given by the function:

$$f_3(Y) = \frac{Y}{Y_{\max}} \times \frac{X_{\max}}{X} - 1 \quad (\text{B.29})$$

where

$Y$  is the output signal due to illumination of the photometer head with an input quantity  $X$ ;

$X_{\max}$  is the input value corresponding to the maximum output signal  $Y_{\max}$  (largest value of the measurement range);

$Y_{\max}$  is the output signal due to illumination of the photometer head with the input  $X_{\max}$ .

The characteristic  $f_3$  is used to characterize by a single value the linearity deviation in each range. It corresponds to the largest value of the function  $f_3(Y)$  within the measurement range:

$$f_3 = \text{Max}[|f_3(Y)|] \quad (\text{B.30})$$

The characteristic  $f_3$  shall be given for each measurement range.

## B.9 Characterization parameter of the display unit

The measurement accuracy of analog-display photometers is determined by the class of analog apparatus (classification by IEC publication 51).

NOTE The classification gives the maximum output error with respect to the full-scale reading.

The resultant characteristic  $f_4$  of a photometer is given by the class of the apparatus:

$$f_4 = k \times (\text{classnumber}) \quad (\text{B.31})$$

where

$k$  is the factor due to changing output range (e.g.  $k = 10$  when the switching of the measurement range is in the ratio of 1:10).

$$k = \frac{Y_{B\max}}{Y_{A\max}} \quad (\text{B.32})$$

where

$Y_{B\max}$  is the full scale reading of the less sensitive range B;

$Y_{A\max}$  is the full scale reading of the more sensitive range A.

The accuracy of digital-display photometers is determined by the deviations in the display unit and the conversion deviations (in general  $\pm 1$  digit). The characteristic is given by:

$$f_4 = \left| f_{\text{display}} \right| + \left| \frac{k \times D}{P_{\text{max}}} \right| \tag{B.33}$$

where

$f_{\text{display}}$  is the relative deviation, related to the display unit;

$k$  is the factor for range changing;

$P_{\text{max}}$  is the maximum display capability of the digital instrument (e.g., for a 3 ½ digit display  $P_{\text{max}} = 1,999$ );

$D$  is the possible deviation of the least significant digit (e.g.,  $\pm 1$  digit).

The characterization and the resulting characteristic  $f_4$  from equation (B.33) are determined by the class of the output apparatus in order to include the largest deviation at the boundary of the range change.

## **B.10 Fatigue**

### **B.10.1 Definition**

Fatigue is the reversible temporal change in the responsivity, under constant operating conditions, caused by incident illumination.

**NOTE** During the operation of photometers, reversible changes can occur in the responsivity as well as in the spectral responsivity. These changes are designated fatigue. Fatigue is generally the greater, the higher the illumination incident on the light-sensitive detector. Fatigue cannot be separated from the temperature effect caused by irradiation of the photometer head. Temperature changes induced by irradiation of the light-sensitive detector are likewise not completely eliminated with thermostatic control.

### **B.10.2 Measurement**

Fatigue shall be measured with temporally stable illumination, at a level close to that used in an actual measurement. The operating conditions (ambient temperature, supply voltage, etc.) shall be held constant. The output signal shall be measured as a function of the illumination period. Before beginning the constant illumination, the photometer head shall not be exposed to light for at least 24 h.

### **B.10.3 Characterization**

The characterization of fatigue is given by the function  $f_5(t)$ :

$$f_5(t) = \frac{Y(t)}{Y(t_0)} - 1 \tag{B.34}$$

where

$t$  is the elapsed time since the beginning of the illumination of the photometer head with the constant illumination;

$Y(t)$  is the output signal at time  $t$ ;

$t_0$  is 10 s; reading begins after illumination for a reference time of 10 s.

To characterize fatigue by only one numerical value, characteristic  $f_5$  is used:

$$f_5 = \left| \frac{Y(t = 30 \text{ min})}{Y(t_0 = 10 \text{ s})} - 1 \right| \quad (\text{B.35})$$

## B.11 Temperature dependence

### B.11.1 Description

Temperature dependence can be characterized as the effect of the ambient temperature on the absolute responsivity and the relative spectral responsivity of the photometer. If the photometer is operated at an ambient temperature different from that used during calibration, measurement errors may occur.

### B.11.2 Measurement

In order to measure temperature dependence, the entire photometer shall be exposed to the desired temperature. The instrument shall attain thermal equilibrium before the measurement has begun.

NOTE 1 In general, it can be assumed that the photometer will attain thermal equilibrium at the desired temperature in about one hour.

NOTE 2 In case there is a fatigue effect, the photometer head should be illuminated only during the measurement. The measurement should be performed at least for ambient temperatures of 15 °C, 25 °C and 40 °C. Photometers which are used in the field should also be measured at an ambient temperature of 5 °C or 0 °C. The measurement should be performed at an illumination level of the photometer head that approaches the largest value of an arbitrary measurement range.

### B.11.3 Characterization

The characterization of temperature dependence is given by the function  $f_6(T)$ :

$$f_6(T) = \frac{Y(T)}{Y(T_0)} - 1 \quad (\text{B.36})$$

where

$Y(T)$  is the output signal at temperature  $T$  ;

$Y(T_0)$  is the 25 °C Reference ambient temperature.

For characterization of temperature dependence the characteristic  $f_6$  is given by:

$$f_6 = \left| \frac{Y(T_2) - Y(T_1)}{Y(T_0)} \times \frac{\Delta T}{T_2 - T_1} \right| \quad (\text{B.37})$$

For photometers used for interior measurement the following values shall be used:

$$T_2 = 40 \text{ °C}; T_1 = 15 \text{ °C}; T_0 = 25 \text{ °C}; \Delta T = 2 \text{ °C}$$

For photometers used for field measurements the following values shall be used:

$$T_2 = 40 \text{ °C}; T_1 = 0 \text{ °C}; T_0 = 25 \text{ °C}; \Delta T = 2 \text{ °C}.$$

## B.12 Evaluation of modulated light

### B.12.1 Description

When measuring modulated light the meter reading of a photometer can deviate from the arithmetic mean value if the frequency of the modulated light is below the lower frequency limit, if the peak overload capability is exceeded or if the settling time is not completed.

### B.12.2 Lower and upper frequency limits

#### B.12.2.1 Definition

The lower frequency limit  $f_l$  (upper frequency limit  $f_u$ ) of sinusoidally modulated light (modulation degree 1, see Figure B.6) is the frequency above (below) which the meter reading does not differ more than 5 % from the reading for unmodulated light of the same arithmetic mean.

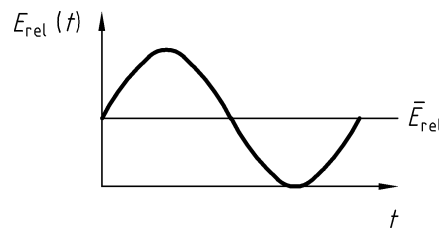

Figure B.6 — Sinusoidally modulated light of modulation degree 1

#### B.12.2.2 Measurement

The measurement of the upper and lower frequency limits can be performed by means of LEDs (Light Emitting Diodes), the luminous intensity of which is modulated sinusoidally by means of a suitable power supply. In this case it is not necessary for the measurement area to be illuminated homogeneously.

Suitable means shall be employed to ensure that the arithmetic mean output of the light source used for the measurement remains constant when the modulation frequency is varied.

Experience shows that the generation of modulated (not sinusoidal) light by means of a rotating-sector disk in combination with a DC-powered lamp can only be used for frequencies up to 104 Hz. Higher illuminances can be achieved by this method, however for a 50 % duty-cycle sector disk the signal level for the measurement of modulated radiation shall be less than half of full scale of the measuring range used. The measuring range should be stated.

#### B.12.2.3 Characterization

The characterization of the frequency effects is given by the function  $f_7(\nu)$ :

$$f_7(\nu) = \frac{Y(\nu)}{Y(\nu_0 = 0 \text{ Hz})} - 1 \quad (\text{B.38})$$

where

$Y(\nu_0 = 0 \text{ Hz})$  is the output signal for illumination with unmodulated light;

$Y(\nu)$  is the output signal for illumination, modulated with frequency, with the same arithmetic mean value as for illumination with steady-state light.

To characterize the effect of modulation using only a single numerical value, the following shall be used:

$$f_7 = \left| \frac{Y(v = 100 \text{ Hz})}{Y(v_0 = 0 \text{ Hz})} - 1 \right| \quad (\text{B.39})$$

## B.13 Range change

### B.13.1 Definition

The deviation arising from a change in the measurement range is the systematic deviation arising when switching a photometer from one range to an adjacent range.

### B.13.2 Measurement

For the measurement of the deviation arising from a range change, the illumination on the photometer head is adjusted to produce a reading of 90 % of full scale on the (lower) range A. The illumination is then increased by a factor k. This factor shall correspond to the factor for range change.

When changing the illumination, the range is changed from A to the next higher range B.

NOTE 1 For photometers with digital displays a range change is usually made in the ratio 1:10. Then k = 10.

NOTE 2 For photometers with a linear input-output relationship (linearity of the photometer) the signal can be simulated by an accurate current source while the photometer head is switched off.

### B.13.3 Characterization

For characterizing the deviation arising from changing range the characteristic  $f_{11}$  is used:

$$f_{11} = \left| \frac{Y_B}{k \times Y_A} - 1 \right| \quad (\text{B.40})$$

where

$Y(A)$  is the reading on range A, for an input quantity  $X(A)$  which corresponds to 90 % of full scale (the maximum reading in the case of digital meters);

$Y(B)$  is the reading on the next higher range (range B) for an input quantity  $X(B)$ , which is a factor k greater than the input quantity  $X(A)$ , and results in a reading of 90 % of full scale (the maximum reading in the case of digital meters) on the smaller range A;

k is the factor defined in B.9;

The characteristic  $f_{11}$  is determined for each range change. The deviations caused by range change shall be listed.

## **Annex C**

### **(normative)**

## **Testing of mirrors for variation in reflectance and flatness**

### **C.1 Test source**

This shall be a light source having a substantially constant intensity in the cone subtended at the photocell by the largest luminaire for which the goniophotometer is designed. A suitable source is an opal filament lamp or a spherical luminaire. The test source shall present a projected area of between 1 500 mm<sup>2</sup> and 5 000 mm<sup>2</sup> in the direction of the optical path to the photocell.

The test source shall be rigidly fixed on a bar having a length equal to that of the longest luminaire for which the goniophotometer is designed, so that the whole of the usable part of the mirror can be covered.

### **C.2 Procedure**

The goniophotometer is set at 0° elevation. The test source is fixed in the vertical axis of rotation and an intensity reading is taken.

The test source is then repositioned on the test bar at a distance from the central position equal to 0,1 times the length of the largest luminaire for which the goniophotometer is designed and redirected towards the photocell. Intensity readings, corrected for the increase in distance between the photocell and the test source, are taken at every 30° in azimuth.

The above procedure is repeated with the test source at distances from the centre position equal to 0,2; 0,3; 0,4; and 0,5 times the length of the luminaire.

### **C.3 Criterion**

The standard deviation of the readings expressed as a percentage of the mean shall not be greater than 1,5 % and each reading shall not differ by more than 5 % from the mean.



## Annex D (normative)

### CEN File Format

#### D.1 Overview

An overview of the complete file format specification is shown below. Each line marked with a double asterisk "\*" is a key line and shall be included in the file even if it does not provide data. Each line marked with a single asterisk "\*" or a double asterisk "\*" shall begin a new line. Descriptions enclosed within the "<" and ">" refer to the actual data stored on that line. All data is stored in the format of ISO Alphabet 5. The length of every line is limited to 78 characters followed by an end of line marker.

NOTE The "\*" and "\*" referred to above are not a part of the file (see examples in Annex E).

```

**  CENF=    CEN File Format, Version 1.0 (EN 13032-1:2004)

*  <label line 1>

*  "

*  "

*  <label line n>

**  IDNM=    <identification number>

*  LUMN=    <luminaire name>

*  MFTR=    <manufacturer>

*  DATE=    <date of issue>

*  TXTS=    <text containing a short description of the luminaire>

*  <short text line 1>

*  "

*  "

*  <short text line n>

*  TXTF=    <text containing a full description of the luminaire>

*  <full text line 1>

*  "

*  "

*  <full text line n>

*  LUMD=    <diameter of a spherical or cylindrical luminaire>

*  LUL1=    <luminaire length along the 1st axis>
  
```

**EN 13032-1:2004 (E)**

\* LUL2= <luminaire length along the 2nd axis>

\* LUL3= <luminaire length along the 3rd axis>

\* LAMP= <lamp name>

\* NLPS= <number of lamps in the luminaire>

\* TOLU= <summation of normal rated lumens of all lamps>

\* LLGE= <lamp-luminaire geometry>

\* BLID= <ballast identification>

\* CONF= <service conversion factor>

\* BAFA= <ballast lumen factor>

\* INPW= <input power in watts>

\* INVO= <input voltage>

\* INVA= <input volt amps>

\* INFH= <input frequency in Hertz>

\* TLNM= <tilt normal in application>

\* LSHP= <luminaire shape code>

\* NLAV= <number of luminous area views to be listed>

\* LA01= <luminous area 1> <plane angle> <cone angle>

\* LA02= <luminous area 2> <plane angle> <cone angle>

\* "

\* "

\* LAnn= <luminous area nn> <plane angle> <cone angle>

\* USR0= <name of user defined section 0>

\* <user line 1>

\* "

\* "

\* <user line n>

\* ENDU=

\* USR1= <name of user defined section 1>

\* <user line 1>

\* "

\* "

```

*   <user line n>
*
*   ENDU=
*
*   "
*
*   "
*
*   USR9=   <name of user defined section 9>
*
*   <user line 1>
*
*   "
*
*   "
*
*   <user line n>
*
*   ENDU=
**
**   PHOT=   INCLUDE or <file-spec>

```

(if PHOT= <file-spec> the file ends at this point.)

(if PHOT= INCLUDE the file continues as follows.)

```

*   <label line 1>
*
*   "
*
*   "
*
*   <label line n>
**
**   PTYP=   <photometric type>
*
*   APOS=   <angle position code>
*
*   TLME=   <tilt during measurement>
*
*   ROME=   <rotation during measurement>
*
*   MTLF=   <Measured Total Luminous Flux>
*
*   ULOR=   <upward light output ratio>
*
*   DLOR=   <downward light output ratio>
*
*   LUBA=   <lumen basis of photometry>
*
*   MULT=   <multiplier>
**
**   NCON=   <number of cone angles>
**
**   NPLA=   <number of plane angles>
**
**   CONA=   <cone angles>
**
**   <1st plane angle> <intensity values for all cone angles at 1st plane angle>
*
*   <2nd plane angle> <intensity values for all cone angles at 2nd plane angle>

```

**EN 13032-1:2004 (E)**

```

*           "
*           "
*           <nth plane angle> <intensity values for all cone angles at nth plane angle>
(if PHOT= <file-spec> the separate file containing the photometric data is as follows:)
**         CENA=   CEN-A File Format, Version 1.0 (EN 13032-1:2004)
*         <label line 1>
*           "
*           "
*         <label line n>
**         PTYP=   <photometric type>
             "
             "
    
```

(the file continues exactly as shown in the case of CENF=)

**D.2 Detailed Description of Data**

Each of the lines given in the overview will now be described in more detail. All lines are structured information lines except where otherwise noted.

CENF= 1.0 CEN File Format (EN 13032-1 2004)

This is a key line which shall be included in the file. The first line of a file always contains a structured statement indicating that this is a CEN file format and including a version number. This is followed by the full name of the format and a reference to the CEN publication that explains the format. The version number is given as a positive real number.

IDNM= or IDentification NuMber =

This is a key line. It signals to the application program that the transmission of information in terms of label lines is completed and that the information that follows is structured. Another purpose is to provide an optional luminaire identification number which can be any sequence of alphanumeric characters.

LUMN= or LUMinaire Name =

The name of the luminaire may be any sequence of printable characters.

MFTR= or ManuFacTuRer =

This line may be used for indicating the name of the luminaire manufacturer, the sales representative, or similar. The name may be any sequence of printable characters.

DATE= or DATE of issue =

This information can be used for updating purposes. The input data for this line shall be in the form of dd/mm/yyyy. For example, 23/10/1995 means the 23rd of October, 1995.

TXTS= or TeXT Short = TeXT for a Short description of the luminaire =

<short text, line 1>

"

"

<short text, line n>

This set of lines can be used to give a short description of the luminaire. This short text might be some part of the label lines in the first section of the CEN file and it is limited to a maximum of 10 lines. For example,

*TXTS= This is a comfort luminaire with opal diffusers and directional signs which provide ideal orientation in hotels, department stores, office blocks, convention centres, galleries, or airports. Body and diffuser of the luminaire are made of impact-resistant polycarbonate.*

TXTF= or TeXT Full = TeXT for a Full description of the luminaire =

<full text, line 1>

"

"

<full text, line n>

This set of lines can be used to give a full description of the luminaire. This information shall not be more than 150 lines.

LUMD= LUMinaire Diameter =

This is a structured line which gives information about the geometrical diameter (in meters) of a spherical or cylindrical luminaire (see Figure D.1).

LUL1= or LUminaire Length along 1st axis =

LUL2= or LUminaire Length along 2nd axis =

LUL3= or LUminaire Length along 3rd axis =

These lines give information concerning the geometrical length (in meters) of the luminaire along the first, second, or third axis, respectively (see Figures 2, 3, 4 and D.1). The input number (if there is one) shall in any case be a real number.

LAMP= or LAMP name =

The name of the lamp(s) may be any sequence of printable characters. The use of ILCOS code acc to IEC ## is recommended.

NLPS= or Number of LamPS =

The number of lamps shall be an integer. Lamps need not be of equal type or physical dimensions.

TOLU= or TOLumens =

This value, a real number, shall be the sum of the nominal luminous flux of all lamps.

LLGE= or Lamp Luminaire GEometry =

This information would be expected in programs which compensate for changes in luminous flux with position (metal halide for example) when the luminaire may be tilted or aimed. If any information is provided the following code shall be used:

**EN 13032-1:2004 (E)**

LLGE= 1 is used when, if the luminaire is mounted normally or aimed straight down, the lamp is either vertical cap up or vertical cap down.

LLGE= 2 is used when, if the luminaire is mounted normally or aimed straight down, the lamp is horizontal, but when the luminaire is tilted, the lamp tends to a base up or base down condition as a result of the luminaire tilt.

LLGE= 3 is used when, if the luminaire is mounted normally or aimed straight down, the lamp is horizontal and remains horizontal when the luminaire is tilted.

LLGE= 4 is used when the lamp is sealed into the luminaire and not replaceable.

BLID= or BaLlast IDentification =

The ballast identification string may be any sequence of printable characters.

CONF= or intensity CONversion Factor = or service CONversion Factor =

This factor takes account of variation on luminaire length and different types of control gear (such as high frequency). It is applied to the basic photometric data file for this variant of the product.

BAFA= or BAAllast lumen FActor =

The ballast lumen factor is a real number.

INPW= or INput Power in Watt =

A real number representing the input power of the total luminaire including losses in the ballast and other components.

INVO= or INput VOltage in Volt =

A real number representing the input voltage for which the luminaire is designed or rated.

INVA= or INput Volt Amps =

A real number representing the volt ampere requirement of the luminaire and all its accessories.

INFH= or INput Frequency in Hertz =

A real number representing the input frequency for which the luminaire is designed or rated.

TLNM= or TiLt NorMal in application =

Shall be a sequence of printable characters representing the range of positive or negative angles of tilt normally used in the application of the luminaire. It is defined as the angle between the first axis of the luminaire and the plumb line from the luminaire to the ground or floor plane, as shown in Figure D.2. The angle is specified in degrees.

An application program may use this information to preset the angle of tilt to a typical value for that luminaire.

LSHP= or Luminaire SHaPe code =

Shall be an integer whose meaning is given by the following code. This information will normally be used for glare calculations. From the shape, area, and the angular direction to which the area applies, the application program can determine the average luminance by using the candela values for that angular direction. If the shape is not precisely defined by the codes 1 to 8, then use code 9 together with a listing of an appropriate number of views (NLAV=, LAnn=). The dimensions of luminous areas according to LSHP = 1 to 8 can be given by the luminous area views.

LSHP= 1 Used when the luminous area is a sphere.

LSHP= 2 Used when the luminous area is half of a sphere in the direction of the first axis.

LSHP= 3 Used when the luminous area is a cylinder in the direction of the first axis.

LSHP= 4 Used when the luminous area is a cylinder in the direction of the second axis.

LSHP= 5 Used when the luminous area is a half cylinder with its axis parallel to the second axis and with the rounded portion in the direction of the first axis.

LSHP= 6 Used when the luminous area is a half cylinder with its axis parallel to the third axis and with the rounded portion in the direction of the first axis.

LSHP= 7 Used when the luminous area is a rectangle or square (four sides) with its normal axis parallel to the first axis of the luminaire.

LSHP= 8 Used when the luminous area is a rectangle or square (four sides) with its normal axis perpendicular to the first axis of the luminaire. In this case at least one luminous area view shall be specified.

LSHP= 9 Used for any other luminous area.

NLAV= or Number of Luminous Area Views =

An integer specifying the number of luminous area views which follow in the form of LAnn=. Numbers between 0 and 99 are permissible.

LA01= or Luminous Area 01 = <luminous area 1> <plane angle> <cone angle>

LA02= or Luminous Area 02 = <luminous area 2> <plane angle> <cone angle>

"

"

LAnn= or Luminous Area nn = <luminous area nn> <plane angle> <cone angle>

Luminous area in square meters that would be seen by an observer located at the plane angle and cone angle listed. Only one plane angle and one cone angle may be listed per view. In the event that the luminous area from the direction needed by the application program is not available, the program may request the needed information to be entered manually or may calculate an approximate area based on the data provided. Number of views limited to 99.

USRn= or USER defined section n = name of user defined section n

This is a structured line the aim of which is to allow a user to create his own section. In this section, the user can give additional information. It is also reserved for information about certain applications, (e.g. emergency lighting). The line has to be started with USRn= and an individual name has to be given to this section. The value of n shall be in the range from 0 to 9. The name of the user defined section shall be alphanumeric with length of the line not exceeding 78 characters. All lines following the structured lines of the user defined section are data lines. An user section ends when a structured line with code name ENDU= is encountered. Any input parameter to the ENDU= line should be ignored by an application program.

ENDU= or END of User defined section =

PHOT= or PHOTometric data =

This is a key line. The primary purpose of this line is to signal to the application program that the first section of the file containing information in terms of physical luminaire characteristics is complete. Depending on the location of the photometric data, one of two versions of this line can be used:

PHOT= INCLUDE Used when the photometric data is part of the CENF= file. This line is immediately followed by the second section of the file.

## EN 13032-1:2004 (E)

PHOT= <file-spec> If any combination of characters other than INCLUDE are used, then this combination of characters is the filename of the separate CENA= file that will be needed by the application program to obtain the photometric information. The current file ends at this point.

### CENA= 1.0 CEN-A File Format (EN 13032-1:2004)

This is a key line which shall be the first line of a CEN photometric data auxiliary file. It contains a structured statement indicating that this is a CEN file format and including a version number. This is followed by the full name of the format and a reference to the CEN publication that explains the format. The version number is given as a positive real number.

### PTYP= or Photometric TYPE =

This is a key line. The purpose of this line is to indicate the type of photometry used.

Luminaires are photometered according to clause 5:

PTYP= C Used when photometry is type (C-gamma) as shown in Figure 3.

PTYP= B Type (B-beta) photometry as shown in Figure 2.

PTYP= A Type (A-alpha) photometry.

### APOS= or Angle POSition code =

This code describes the location of the zero plane and zero cone. When transferring data to or from a different file format it may be necessary to relabel the planes and cones to conform to the conventions required by that format. The APOS= code is also used to give information about the symmetry of the luminous intensity distribution.

APOS= C1 Luminaire to be used for road lighting applications. The 0 to 180 degree plane is designated as the plane parallel to the edge of the road or parallel to a line tangent to a curved road. The 90 degree plane crosses the carriageway when the luminaire is mounted directly above the kerb. A luminaire whose distribution is asymmetric relative to the 90 to 270 degree plane should place the maximum intensity in the hemisphere containing the 0 degree plane.

APOS= C2 General purpose luminaire with mounting fittings for field adjustment of the luminaire, (e.g., wall or track mounted luminaires and floodlights). The 0 to 180 degree plane is parallel to the second axis and the 270 degree plane extends from the luminaire photometric *centre* through the location of the mounting fitting.

APOS= C3 Completely rotationally symmetric luminaire. The light distribution is the same in all planes.

APOS= C4 Luminaire with one plane of symmetry, namely the 90 to 270 degree plane.

APOS= C5 Luminaire with one plane of symmetry, namely the 0 to 180 degree plane.

APOS= C6 Luminaire with two perpendicular planes of symmetry, namely both the 90 to 270 degree plane and the 0 to 180 degree plane.

APOS= C7 Luminaire with no planes of symmetry.

Codes C3 to C7 designate general purpose luminaires with no mounting fittings for field adjustment. Except in the case of full rotational symmetry (C3), where any plane may serve as the 0 plane, the manufacturer should mark the luminaire with the location of the 0 degree plane or relate it to some recognizable part of the luminaire. A description of the mark or recognizable part would normally be included in the label lines. If the light source is (or parallel light sources are) elongated, the 0 to 180 degree plane is perpendicular to the longer dimension of the light source (in this case no mark or recognizable part of the luminaire is needed when APOS= C6).

When used with type (B, beta) or type (A, alpha) photometry the 0 cone angle is located at the equator. The angle increases to +90 degrees at one end of the polar axis and decreases to -90 degrees at the other. The location of



the fittings that permit field adjustment determine whether angles increase or decrease (see Figure 2). The following code should be used to locate the 0 degree plane.

APOS= B1 (APOS= A1 in the case of type (A, alpha) photometry)

Luminaire whose light distribution is the same in all planes. Any plane may serve as the 0 degree plane.

APOS= B2 (APOS= A2)

Luminaire with one plane of symmetry, namely the B0 to B180 (A0 to A180) degree plane.

APOS= B3 (APOS= A3)

Luminaire with no plane of symmetry.

APOS= B4 (APOS= A4)

Luminaire with no mounting fittings for field adjustment. In this case the manufacturer shall mark the luminaire with the location of the 0 degree plane or relate it to some recognizable part of the luminaire. A description of the mark or recognizable part would normally be included in the label lines.

B1CS, B2CS, B3CS, and A1CS, A2CS, A3CS codes (CS means cone symmetry) should be used when the luminous intensity distribution is as defined above but also has symmetry around the 0° cone angle.

TLME= or TiLt during MEasurement =

Shall be a real number representing the angle of tilt in degree during measurement. When using type (C, gamma) photometry, the luminaire is sometimes located in the spherical co-ordinate system with the first luminaire axis (Figure 4) not parallel to the polar axis. In this case the measurement tilt may be a positive or negative number of degrees. Figure D.2 defines positive and negative tilt when included in the photometric measurements.

It depends on the difference of the values of tilt used in the application and the TLME= value, whether the photometric grid shall be tilted for the determination of luminous intensity values.

e.g.:

default value is 0 (nearly all interior luminaires);

for a street lantern, the design tilt or design attitude represents, in degrees, the slope of the luminaire when photometred;

for a floodlight, the design tilt represents the angle, in degrees, between first photometric axis of the luminaire and a defined mechanical feature such as the normal to the front glass.

ROME= or ROtation during MEasurement =

Shall be a real number representing any angular displacement of the luminaire around its third axis during measurement. Positive values indicate counterclockwise rotation when viewed into the positive direction of the third axis (see Figure D.3). Value is given in degrees.

MTLF= or Measured Total Luminous Flux =

This value, a real number, shall be the sum of the measured luminous flux of all lamps according to clause 5.5.

ULOR= or Upward Light Output Ratio =

DLOR= or Downward Light Output Ratio =

The values of the upward and/or downward light output ratios are given as non-negative real numbers.

## EN 13032-1:2004 (E)

LUBA= or LUmen BAis of photometry =

This parameter is a real number. The luminous intensities are conventionally expressed in cd/1 000 lm. However another basis such as per 100 lm or per 10 000 lm may be used. A negative parameter value (e.g. -1) indicates intensities in cd. If this parameter is not given the luminous intensities are expressed in cd/1 000 lm.

MULT= or MULTiplier =

A real number by which all intensity values in the file shall be multiplied to obtain the proper intensity values. The use of a multiplier allows all intensity values to be given with a reasonable number of digits.

NCON= or Number of CONE angles =

NPLA= or Number of PLane Angles =

These lines are key lines. The parameters are integers specifying the total number of cone angles and the total number of plane angles in the photometric report for which intensity values will be transmitted.

CONA= or CONE Angles =

This is a key line. The cone angles for which intensities are given shall be listed in ascending order. Any of the values can be continued on additional lines, if necessary. Values are real numbers and in degree.

<1st plane angle> <intensity values for all cone angles at 1st plane angle>

<2nd plane angle> <intensity values for all cone angles at 2nd plane angle>

"

"

<nth plane angle> <intensity values for all cone angles at nth plane angle>

These lines are not preceded by a structured name. Instead, the plane angles for which data is present in the photometric report shall be listed in ascending order. Angles are real numbers and specified in degree.

Intensity values (real numbers) corresponding to each cone angle of the designated plane angle follow. The order of the values shall exactly correspond to the list given with CONA=. Any of the values called for above may be continued on additional lines, if necessary.

### D.3 Conventions for Programmers

- a) All lines are limited in length to a maximum of 78 characters plus the terminating end-of-line-marker. Totally blank lines are permissible. They shall be ignored, except in the case of TXTS= or TXTF= blocks.
- b) Structured lines begin with a 5 character code name where the last character is "=" . The program shall be capable of deleting lower case letters and spaces from the code name.
- c) Real numbers may also be given in integer notation (without a decimal point).
- d) The order of code names within one section as given in the file format overview is recommended, but not obligatory. An application program looking for certain parameters shall be able to scan the entire section. However, all key lines shall be entered in the specified order.
- e) The individual values on any one line shall be separated by a valid separator, which shall not be capable of confusion with a valid data field.
- f) Only one set of photometric data for one luminaire is permitted per file.

- g) It is not necessary to include each and every structured line in each file, however all key lines shall be included.
- h) Each structured line shall only appear once in a file.
- i) File names shall be constructed according to ISO 9660. Names of drives and/or paths are not part of the file name.
- j) The extension of the file name shall be ".CEN".

.....

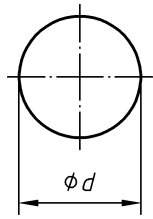

ITYP = 1 and LUMO = d

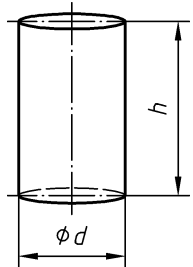

ITYP = 4, LUMO = d, LUL1 = 1

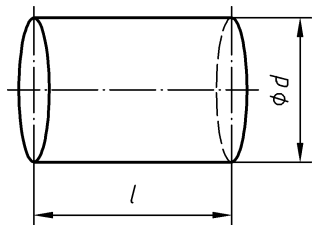

ITYP = 4, LUMO = d, LUL1 = h

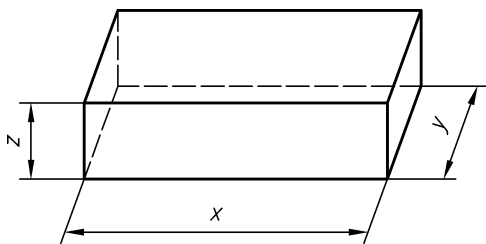

ITYP = 2, LUL3 = x, LUL2 = y, LUL1 = z

Figure D.1 — Examples of geometry of a luminaire

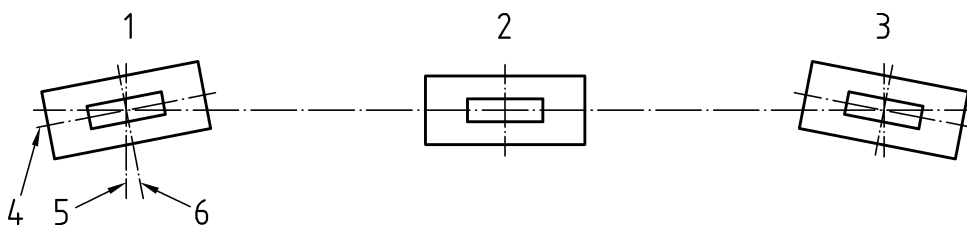

**Key**

- 1 Positive angle
- 2 Zero angle
- 3 Negative angle
- 4 Second axis
- 5 Polar axis
- 6 First axis

Figure D.2 — Definition of angles of tilt

## Annex E (informative)

### Examples of the CEN File Format

#### E.1 Example 1

CENF= CEN File Format Version 1.0 (EN 13032-1:2004)

IDNM= 304

MFTR= Luminaire Manufacturer, Europe

DATE= 10/02/1995

TXTS= Industrial reflector luminaire for high-pressure mercury, metal halide,  
and sodium vapour lamps.

TXTF= Industrial reflector luminaire for high-pressure mercury, metal halide,  
and sodium vapour lamps.

This luminaire is designed for use on industrial and commercial premises  
at heights of 4 m or more above the working plane.

The body of the luminaire is made of zinc-coated sheet steel with white stove  
enamel finish. The luminaire reflector has been made of high-purity aluminium,  
anodized in matt silver.

LUMN= QBE 400W

LAMP= 400 watt HME

NLPS= 1

TOLU= 20000

LUMD= 0.59

LUL1= 0.67

BAFA= 1

PHOT= INCLUDE

PTYP= C

LUBA= 1000

MULT= 1

NCON= 19

## EN 13032-1:2004 (E)

NPLA= 1

CONA = 0 5 10 15 20 25 30 35 40 45 50 55 60 65 70 80 85 90

0 369.1 365.4 357.6 382.2 420.9 430.2 388.2 318.9 246.8 185.5

133.4 87.5 53.1 30.3 15.7 5.4 1.4 0.5 0.3

### E.2 Example 2

CENF= CEN File Format Version 1.0 (EN 13032-1:2004)

Example of the CEN File Format using long names.

IDentification NuMber= 7259

ManuFacTuRer= Luminaire Manufacturer, Europe

DATE of issue= 10 / 02 / 1995

TeXT Short= This luminaire is made for modern offices, sales areas and show rooms.

TeXT Full= This luminaire is designed for modern offices, sales areas and show rooms.

The luminaire body is made of sheet steel, white stove enamelled.

The reflector is high-purity aluminium. For lamp maintenance, the reflector can be suspended from coil springs which also serve as the ground connection.

LUMinaire Name= RED-B 4/18 Breit MN725

LAMP name= 18 Watt DAYLIGHT

Number of LamPS= 4

TOtal LUMens= 5400

LUMinaire Length along the 1st axis= 0,094

LUMinaire Length along the 2nd axis= 0,623

LUMinaire Length along the 3rd axis= 0,623

BaLlast IDentification= 200-240/250/260

BAllast FActor= 1

INput Volt Amperes= 243

Luminaire SHaPe= 8

Number of Luminous Area Views= 0

USR0=Photo

see graphical data in filename PHOTFILE.EXT

PHOTometric file= INCLUDE

Photometric TYPE= C

TiLl during MEasurement= 0

LUMen BAis of photometry= 1 000

MULTiplier= 1

Number of CONe angles= 19

Number of PLane Angles= 7

CONe Angles= 0 5 10 15 20 25 30 35 40 45 50 55 60 65 70 75 80 85 90

0 247.3 263.2 293.4 327.5 366.8 395.8 383.4 345.4 283.6 190.4 86.3 4.1

0.5 0.4 0.2 0.1 0.1 0.1 0.1

15 247.3 270.0 299.4 333.2 369.4 393.3 375.9 333.3 267.8 177.7 98.9 4.9

1.0 0.5 0.2 0.1 0.1 0.1 0.1

30 247.3 259.6 284.2 310.8 342.1 369.6 375.7 347.1 295.5 219.3 120.6 29.2

2.3 1.3 0.3 0.2 0.1 0.1 0.2

45 247.3 260.0 278.1 296.9 316.0 334.3 345.7 328.8 287.5 224.6

129.9 41.1 4.4 1.3 0.1 0.1 0.1 0.2 0.2

60 247.3 250.4 260.4 268.5 276.1 282.5 289.3 291.5 282.7 250.3

164.3 57.1 12.4 1.8 0.3 0.3 0.2 0.2 0.2

75 247.3 247.4 247.3 246.3 243.4 238.7 231.9 222.7 211.3 194.9

137.1 50.6 7.7 0.3 0.2 0.2 0.2 0.2 0.2

90 247.3 246.3 242.9 236.9 227.5 217.6 204.7 189.1 168.9 146.3

100.2 46.0 0.5 0.3 0.3 0.2 0.2 0.3

www.lisungroup.com

## Bibliography

CIE 69:1987<sup>13)</sup>, *Methods of characterizing illuminance meters and luminance meters: Performance, characteristics and specifications.*

CIE 70:1987<sup>13)</sup>, *The measurement of absolute luminous intensity distribution.*

CIE 84:1989<sup>13)</sup>, *Measurement and luminous flux.*

CIE 102:1993<sup>13)</sup>, *Recommended file format for electronic transfer of luminaire photometric data.*

CIE 121:1996<sup>13)</sup>, *The photometry and goniophotometry of luminaires.*

IEC/TS 61231, *International Lamp Coding System (ILCOS).*

---

<sup>13)</sup> The official CIE documents can be obtained from CIE National Committees or from the CIE Central Bureau (Kegelgasse 27, A-1030 Vienna, Austria).